

# Network Camera

AXIS 2120



## User's Manual v1.2

### Document Version Control - Notice

This is the latest published version of the AXIS 2120 User's Manual. Superseding versions of this document are regularly published in PDF format on the Axis Website at: [www.axis.com](http://www.axis.com).

All modifications to this document are controlled through strict version control and are generally implemented to:

- (i) reflect improvements in the product functionality that are introduced through new firmware releases,
- (ii) amend any anomalies that become apparent, and/or
- (iii) to improve general readability of the document.

We would therefore urge you to check this document version against the latest version published on our Website. Thank you.

## About This Document

This document is intended for both administrators and users of the AXIS 2120 Network Camera, and is applicable for software release 2.12. As a complement to the Installation Guide supplied with your product, this document contains information for configuring, managing and using the unit, as well as a general overview of the product functionality. Detailed instructions for using the product are also available in the on-line Help.

Readers are recommended to use this document as a supplement to the Wizards and other on-line information available via the Web-based interface. Superseding versions for this document will be posted to the Axis Website, as and when required.

## Safety Notices

Please observe these safety markings when using this product.

**Caution!** - Potential hazard that can damage the product.

**Important!** - Potential hazard that can seriously impair operation.

Do not proceed beyond any of the above notices until you have fully understood the implications.

## Legal Considerations

Camera surveillance may be prohibited by laws that vary from country to country. Check the laws in your local region before using the AXIS 2120 for surveillance.

## Electromagnetic Compatibility (EMC)

**USA** - This equipment generates, uses, and can radiate radio frequency energy, and if not installed and used in accordance with the instruction manual, may cause interference to radio communications. It has been tested and found to comply with the limits for a Class A computing device pursuant to Subpart B of Part 15 of FCC rules, which are designed to provide reasonable protection against such interference when operated in a commercial environment. Operation of this equipment in a residential area is likely to cause interference in which case the user at his/her own expense will be required to take whatever measures may be required to correct the interference. Shielded cables should be used with this unit to ensure compliance with the Class A limits.

**Europe** **CE** - This digital equipment fulfills the requirements for radiated emission according to limit B of EN55022/1994, and the requirements for immunity according to EN55024/1998 residential, commercial, and light industry.

## Liability

Every care has been taken in the preparation of this manual; if you detect any inaccuracies or omissions, please inform your local Axis office which can be found on the cover of this document. Axis Communications AB cannot be held responsible for any technical or typographical errors and reserves the right to make changes to the product and manuals without prior notice. Axis Communications AB makes no warranty of any kind with regard to the material contained within this document, including, but not limited to, the implied warranties of merchantability and fitness for a particular purpose. Axis Communications AB shall not be liable nor responsible for incidental or consequential damages in connection with the furnishing, performance or use of this material.

## Trademark Acknowledgments

Acrobat, Adobe, Boa, Ethernet, IBM, Internet Explorer, LAN Manager, Linux, Macintosh, Microsoft, Netscape Navigator, OS/2, UNIX, Windows, WWW are registered trademarks of the respective holders. Java and all Java-based trademarks and logos are trademarks or registered trademarks of Sun Microsystems, Inc. in the United States and other countries. Axis Communications AB is independent of Sun Microsystems Inc.

## Support Services

Should you require any technical assistance, please contact your local dealer. If your questions cannot be answered immediately, your dealer will forward your queries through the appropriate channels to ensure a rapid response. If you are connected to the Internet, you can obtain on-line manuals, technical support, software updates, application software and general corporate information from [www.axis.com](http://www.axis.com).

AXIS 2120 User's Manual

Revision 1.2

Part No: 18647

Dated: May 2001

Copyright © Axis Communications AB,  
1996 - 2001

# Table of Contents

<b>Product Overview</b> .....	<b>5</b>
Features and Benefits .....	6
<b>Physical Description</b> .....	<b>8</b>
Front Panel .....	8
Rear Panel .....	9
<b>Assembling Your Camera</b> .....	<b>10</b>
Checking the Hardware Inventory .....	10
Connecting the AXIS 2120 to a Mounting Assembly .....	11
<b>Installing Your Camera on a Network</b> .....	<b>12</b>
Quick Installation Procedure .....	12
Verifying the Installation From Your Browser... ..	14
Alternative Methods of Assigning the IP Address .....	15
Notes for Macintosh Users .....	18
<b>Installing Your Camera to a Modem</b> .....	<b>19</b>
Before You Begin .....	19
<b>Configuring Your Camera</b> .....	<b>25</b>
Configuration Using the Wizards .....	25
The Administration Tools .....	26
System Security .....	30
Motion Detection .....	31
Reinstating the Factory Default Settings .....	33
<b>Choosing Your Application</b> .....	<b>34</b>
Networking Applications .....	34
Modem Applications .....	39
<b>Adjusting the Camera Focus</b> .....	<b>44</b>
Direct Focusing in Your Browser .....	44
Using the The Focus Assistant .....	45
Replacing the Lens .....	47
Adjusting the DC-Iris Settings .....	47
Adjusting the Back Focus .....	49
<b>Appendix A - Troubleshooting</b> .....	<b>50</b>
Frequently Asked Questions .....	50
PINGing Your IP Address .....	51
Symptoms, Possible Causes and Remedial Actions .....	52

<b>Appendix B - Updating the Software</b> .....	<b>55</b>
Obtaining Updated Software .....	55
Upgrading the Software .....	55
<b>Appendix C - The Unit Connectors</b> .....	<b>56</b>
<b>Appendix D - High Speed Services</b> .....	<b>60</b>
<b>Appendix E - Custom Web Pages</b> .....	<b>62</b>
Customizing Procedures .....	62
<b>Appendix F - Technical Specifications</b> .....	<b>65</b>
<b>Index</b> .....	<b>67</b>
<b>Glossary of Terms</b> .....	<b>68</b>

---

## Product Overview

The AXIS 2120 is a digital network camera running TCP/IP. It includes all of the required networking connectivity for distributing monitored images over a secure intranet network or the Internet. With its own built-in Web server, the AXIS 2120 provides high-quality imaging, and full Web-based control of the product management and configuration functions through a browser over your network.



Connecting directly to Ethernet or Fast Ethernet networks, the AXIS 2120 is a standalone digital network camera that will also connect to a local Internet Service Provider using an external modem.

To simplify the installation process, the Web-based interface features several user-sensitive Wizards that provide a seamless and automated integration into your networking and application environments. Its open-network structure minimizes the need for costly and complex coaxial cabling, to offer a cost-effective intranet and Internet imaging solution with minimal installation costs.

## Features and Benefits

**Easy to Use** - The AXIS 2120 is completely independent of any other server and requires no other special hardware or software such as PC frame grabber cards or viewing software. All you need is Netscape Navigator 4.x or above. Alternatively, you can use the Axis ActiveX component for Microsoft Internet Explorer 4.x or above. If your computer does not allow you to use ActiveX components, use the Java Applet instead. The AXIS 2120 has complete plug-and-picture functionality - all you need do is assign a valid IP address.

**Open Standards Environment** - Supporting TCP/IP networking, SMTP e-mail, HTTP and other Internet-related protocols, the AXIS 2120 can be used in mixed operating system environments such as; Windows, UNIX, Macintosh and OS/2. It integrates easily into other WWW/Intranet applications and CGI scripts.

**Simple Administration** - Using a standard browser, you configure and manage the AXIS 2120 directly from its own Web pages. Image control, time stamping and text overlays are all accessible from the tools.

**Outdoor Use** - The AXIS 2120 has a varifocal DC Iris lens that automatically regulates the amount of light entering the camera, and provides a wide-angle zoom with minimal distortion. With a standard CS-mount, this lens can easily be replaced by any other lens conforming to the same standard. When installed in an appropriate outdoor housing, the AXIS 2120 is the ideal remote monitoring solution for outdoor use. For sales information on appropriate outdoor casings for the AXIS 2120, please see the product pages for the AXIS 2120 at [www.axis.com](http://www.axis.com).

**Motion Detection** - Sophisticated motion detection with in-picture alarm programming, and exclusive multi-window triggering for non-critical remote monitoring.

**Standard Image Format** - The AXIS 2120 delivers complete, high-quality pictures in standard JPEG format, which can be viewed using any standard browser.

**Image Updating** - The on-board AXIS ETRAX 100 processor combined with the revolutionary AXIS ARTPEC-1 Real Time Picture Encoder provides an amazing power-synergy to deliver up to 25 frames/second over 10Mbps or 100Mbps networks.

**High Compression** - The AXIS ARTPEC chip provides efficient compression of JPEG images and allows the variable compression ratio to be defined by the user.

**External Device Connection** - Supporting an auxiliary Input/Output Connector, you can connect your AXIS 2120 to a variety of external devices; such as, IR-sensors, switches and alarm relays. In combination with the programmable alarming facilities, you can quickly develop a variety of security applications that are triggered on time or alarm-based events.

**Wide Range of Applications** - The AXIS 2120 offers live video over internet networks and the Internet, and is ideal for use with many of today's high-speed internet services. Allowing remote access directly from your browser, you can view live images, manage and control the AXIS 2120 at any time and anywhere. Use it for intruder detection, process control, industrial and public monitoring, image archiving, or any other application.

**Modem Support** - The Point to Point Protocol (PPP) support allows you to use your AXIS 2120 remotely over a serial link, just as if it were located on your local network. After initially setting up the unit using a local connection to a computer, you can then configure the unit for remote use over an external modem.

**ISP Support** - Arrange for the image files to be uploaded to an Internet Service Provider (ISP) and you can provide the global Internet community with browser access to your live images. Select any supported ISP from the Web-based Wizards, or choose your own ISP as an imaging repository for your images.

**Security** - The AXIS 2120 includes a self-contained Web server, which means that your digital images can be protected just like any other Internet host. Data protection is normally implemented by your Network Administrator using the unit security settings in combination with an organization's Internet firewall. The Administrator can subsequently restrict image access to specific individuals, groups of user, company staff... or the whole Internet community.

**Linux Operating System** - The AXIS 2120 includes modified versions of the Boa Web server, and Linux operating system - both of which are freely distributed under the GNU General Public License, as published by the Free Software Foundation. This software provides a stable and reliable platform for open-source development of the product.

In accordance with the *GNU General Public License*, Axis has published the kernel for this product at <http://developer.axis.com/>.

**AXIS Technology** - Axis renowned chipset technology is built upon an open architecture that is streamlined to provide device connectivity independent of any file server. The AXIS 2120 is driven by a powerful AXIS ETRAX 32-bit RISC processor and includes the industry's first dedicated digital video remote monitoring compression chip - the AXIS ARTPEC-1.

## Physical Description

Read the following information to familiarize yourself with the AXIS 2120, making particular note of where the connectors and indicators are located. As a supplement to the information provided in the Quick Installation Guide, this section provides a useful reference when installing the product.

### Front Panel

#### ● Status Indicator

Used in conjunction with the Focus Assistant, this multi-colored indicator can be used as a local focusing aid (for further details please refer to *Adjusting the Camera Focus*, on page 44). However, under normal conditions this indicator defines the operational status of the camera, as described below:

- green - the indicator flashes briefly and momentarily displays orange during the start-up and self-test routines; the indicator then displays green to indicate a healthy unit status.
- red - the indicator will display red only if a problem with the AXIS 2120 has occurred. Refer to *Appendix A - Troubleshooting*.

Note: The Status Indicator also displays orange when setting the factory default settings, as described in *Reinstating the Factory Default Settings*, on page 33.

#### ● Control Button

Located to the left of the lens assembly; this button is recessed within the product casing. Using a suitably pointed object, press this button to restore the factory default settings as described in *Reinstating the Factory Default Settings*, on page 33; and to enable the Focus Assistant, as described in *Adjusting the Camera Focus*, on page 44.



#### ● Lens Assembly

Includes a wide angle lens with rotational focus control.

The supplied lens is removable and can be replaced with any standard C/CS-mounted lens.

#### ● Serial Number

Located on the underside label of the AXIS 2120, the serial number is identical to the Ethernet address of the unit.

### Caution!

Although the AXIS 2120 Network Camera is supplied with a varifocal DC auto-Iris lens that automatically regulates the amount of light into the camera, prolonged exposure to direct sunlight or halogen light may damage the CCD. Consequently, Axis recommends extreme caution when installing your product in strong sunlight, as failure to do so may invalidate your product warranty.



## Rear Panel

### RS-232 Serial Connector

Single 9-pin D-sub connector providing the RS-232 serial interface for modem connection. For pinout information, refer to *Appendix C - The Unit Connectors*.

### I/O Connector

Provides the physical interface to a digital output, and a single digital photo-coupled input that is used for connecting a variety of external alarm devices to the AXIS 2120 including, IR-sensors, switches and alarm relays. In combination with the configurable alarm facilities, you can quickly develop a variety of security applications that are triggered on time - or alarm based - events. The connector can also be utilized as an alternative connection point for DC power to the unit. For pinout information, refer to *Appendix C - The Unit Connectors*.

### Power Supply Connector

A single Jack socket (PS-D) for connection of the AXIS 2120 power supply. The terminal block connector provides an auxiliary connection point for AC or DC power to the unit.

### Network Connector

The AXIS 2120 is designed for 10 Mbps Ethernet and 100 Mbps Fast Ethernet networks and connects to the network via a twisted pair category 5 cable (10baseT and 100baseTX), terminated using a standard RJ-45 connector. Supporting NWAY, the AXIS 2120 detects the speed of the local network segment and varies the speed of data communication accordingly (between 10 Mbps and 100 Mbps)..

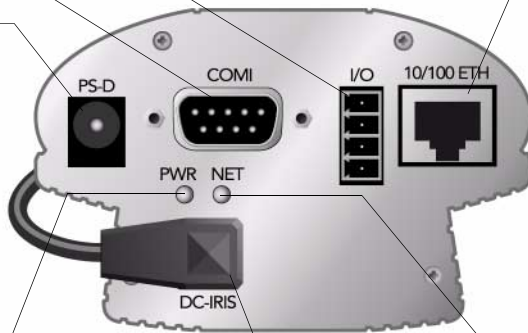

### Power Indicator

Normally lit when power is applied. If it is not lit, or it flashes, there is a problem with the AXIS 2120 external power supply.

### DC-Iris Connector

With the DC-Iris cable connected to the lens upon delivery, this socket provides the power and electronic signalling to the lens of the AXIS 2120. For instructions on how to change the DC Iris settings, refer to *Adjusting the DC-Iris Settings*, on page 47.

### Network Indicator

After completion of the startup and self test routines, this multi-colored indicator flashes independently, as follows:

- yellow - activity on a 10Mbps network
- green - activity on a 100Mbps network
- red - no physical connection to the network

**Note:** The power supply supplied with your AXIS 2120 is country specific. Please check that the type of power supply you are using is correct. See page 10.

## Assembling Your Camera

The information provided in this section will assist you in unpacking and assembling the product correctly. Once assembled, you are then ready to install and configure your product, as described in the following sections of this document.

### Checking the Hardware Inventory

Unpack and check all the items against the itemized list below. You should contact your dealer immediately if you find anything is missing or damaged.

Hardware	Title/Variants	Part Numbers
<b>Network Camera</b>	AXIS 2120 50 HZ (without power supply)	0126-001-01
	AXIS 2120 50 HZ Europe	0126-002-01
	AXIS 2120 50 HZ UK	0126-003-01
	AXIS 2120 50 HZ Australia	0126-006-01
	AXIS 2120 60 HZ (without power supply)	0126-011-01
	AXIS 2120 60 HZ Europe	0126-012-01
	AXIS 2120 60 HZ US	0126-014-01
	AXIS 2120 60 HZ Japan	0126-015-01
	AXIS 2120 60 HZ Australia	0126-016-01
	<b>Null Modem Cable</b>	-
<b>Mounting Assembly</b>	-	15104
<b>Power Supply (PS-D)</b>	Europe	14233
	UK	14234
	Australia	14255
	USA	14253
	Japan	14254
<b>PS-D Extension Cable</b>	3.3 meter	15187
<b>Printed Materials</b>	AXIS 2120 Installation Guide v1.0 (or later)	17618
	Product Warranty Document	18489
<b>Disk Media</b>	AXIS Network Camera CD v1.1 (or later)	-

**Important!**

60Hz and 50Hz variants of the AXIS 2120 are available to accommodate the different power supply frequencies found in the USA and Europe.

The 60Hz variant delivers a resolution of 525 lines of at 60 half-frames per second and is suitable for use in the United States; whereas, the 50Hz variant delivers 625 lines at 50 half-frames per second and is appropriate for use in Europe.

**Connecting the AXIS 2120 to a Mounting Assembly**

**Caution!**

Although the AXIS 2120 Network Camera is supplied with a varifocal DC auto Iris lens that automatically regulates the amount of light into the camera, prolonged exposure to direct sunlight or halogen light may cause damage to the CCD. Consequently, Axis recommends extreme caution when installing your product in strong sunlight, as failure to do so may invalidate your product warranty.

The mounting assembly supplied with your AXIS 2120 features a screw head that attaches to the underside of the product. Fasten the AXIS 2120 to the mounting assembly and position it appropriately for your application. The three holes in the base unit allow the product to be securely fastened to any wall.



## Installing Your Camera on a Network

- Macintosh users - Please refer to *Notes for Macintosh Users*, on page 18.
- Easy installation - Use The AXIS IP Installer. See *Using the AXIS IP Installer*, on page 16.
- Quick installation- Follow the instructions below to install the AXIS 2120 on an Ethernet network.

### Important!

- For details on how to install the AXIS 2120 to a modem, see *Installing Your Camera to a Modem*, on page 19.
- If you are using your AXIS 2120 in an outdoor application, the unit must be housed in an outdoor enclosure. Please see the Axis Website at: [www.axis.com](http://www.axis.com) for suppliers details.
- Do not use the default or IP address featured in the following examples when installing your AXIS 2120. Acquire an unused IP address from your Network Administrator.
- Server Privileges: Although no special privileges are required for Windows 95/98, you do need *Administrator* privileges for Windows NT/2000, and *Root* privileges on UNIX.

## Quick Installation Procedure

Follow the instructions below to quickly install the AXIS 2120 onto an Ethernet network:

### ① Note the Serial number

Note the Serial number on the underside of the unit. You need to know this to set the IP address:

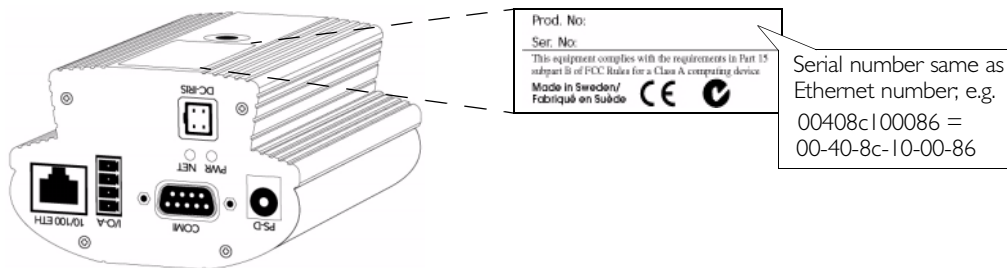

### ② Assign an IP Address

Using an appropriate method for your operating system, assign your AXIS 2120 with a unique IP address from a computer on your network, using the ARP command, as follows:

**Windows 95/98 & NT/2000 only** - Start a DOS window and type these commands:

Syntax:

```
arp -s <Camera IP address> <Ethernet address> <my PC IP address>
ping -t <Camera IP address> -t
```

Example:

```
arp -s 172.21.1.200 00-40-8c-10-00-86 172.21.1.193
ping -t 172.21.1.200 -t
```

**UNIX only** - Type these commands in your command line:

Syntax:

```
arp -s <IP address> <Ethernet address> temp
ping <IP address>
```

Example:

```
arp -s 172.21.1.200 00:40:8c:10:00:86 temp
ping 172.21.1.200
```

You will now see 'Request timed out...' messages repeatedly returned in the window.

**Notes:** •In Windows you can find out the IP address of your workstation by running **winipcfg** (Win 95/98) or **ipconfig** (Win NT/2000) from the command line.

•See also *Alternative Methods of Assigning the IP Address*, on page 15.

**3 Connect an Ethernet cable**

Connect an Ethernet cable to your AXIS 2120 and attach it to the network.

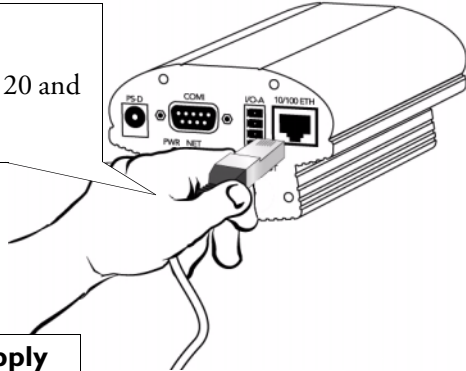

**4 Attach the external Power Supply**

Attach the external Power Supply to the unit and connect it to your local power supply.

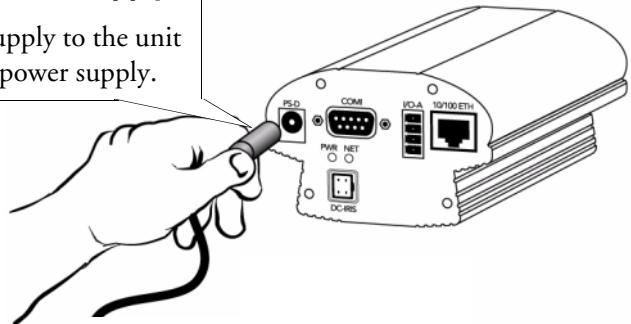

**5 Wait for ARP reply and check Network indicator**

Approximately 10-15 seconds after connecting the power supply, the message 'Reply from 172.21.1.200...' - or similar, is returned in the window. Ensure that the Power Indicator is permanently lit and that the Network Indicator flashes intermittently.

**6 Exit ping and check the installation.**

The installation is now complete, and you are now ready to access the AXIS 2120 from your Web browser, as described in the next section...

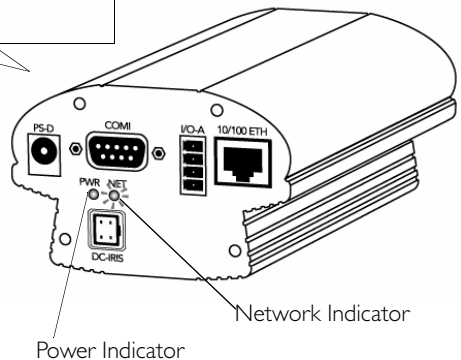

## Verifying the Installation From Your Browser...

Having completed the installation procedure above, you should then verify the connection between the AXIS 2120 and the network, as follows:

1. Start your browser (see note below) and enter the name or IP address in the **Location/Address** field:

**Example:**

http://172.21.1.200/

The **Home Page** for your AXIS 2120 is now displayed:

The screenshot displays the web interface of the AXIS 2120 Network Camera. At the top left is a green graphic with a camera icon. The main content area is titled "Live web imaging unleashed." and shows a live video feed of a playroom. Below the video is a yellow taxi image with a "Demo web" link. To the right is a navigation menu with "Installation Wizard" and "Administration Tools" links. The AXIS Communications logo is in the bottom right corner.

### Important!

To enable the updating of images in Microsoft Internet Explorer, you must set your browser to allow ActiveX controls and perform a once-only installation of Axis' ActiveX component onto your workstation. However, if your computer environment restricts or prohibits the installation of additional software components, you can alternatively set your AXIS 2120 to use a Java applet for updating the images. This is done from Image settings in the Administration Tools.

2. Continue the setup process and configure your own application using the **Installation Wizard** or **Administration Tools**, as described in *Configuring Your Camera*, on page 25.

**Important!**

When accessing the Administrator Tools for the first time during a browser session, you will not be prompted for your username and password. You will be assumed to be the Administrator and will be automatically logged on as such, using the username root and the default password pass. This root password must, however, be changed as soon as possible, to enable the security function. Furthermore, all Axis products are shipped with the same password as default. For further information, refer to *System Security*, on page 30.

**Alternative Methods of Assigning the IP Address**

In addition to the ARP command (as described earlier in this section), you can set the IP address using an appropriate method for your operating system from the table below:

- Do not use the default or IP address featured in the following examples when installing your AXIS 2120. Consult your Network Administrator and acquire an unused IP address.
- Make sure the AXIS 2120 is powered up and attached to the network.
- Server Privileges: Although no special privileges are required for Windows 95/98, you do need *Administrator* privileges for Windows NT/2000, and *Root* privileges on UNIX systems.
- Ethernet Address: The AXIS 2120 is pre-configured with a unique Ethernet Address based upon the serial number printed on the underside label of the unit; where the serial number typically follows the format 00-40-8c-xx-yy-zz. You must know the Ethernet address to complete the installation.

Method	Operating Systems	Refer to...
<b>AXIS IP Installer</b>	Windows 95/98 and NT/2000	<i>Using the AXIS IP Installer, on page 16.</i>
<b>BOOTP</b> Requiring a BOOTP daemon on your system, this method operates over the entire network. A request to an active daemon initiates a search of the boot table to find an entry matching the unit's Ethernet address. The daemon downloads the IP address to the device if a match is found.	UNIX	<i>Using BOOTP in UNIX, on page 17.</i>

## Using the AXIS IP Installer

The AXIS IP Installer is a Windows 95/98 & NT/2000 program that is ideal for setting the IP addresses for multiple Axis products on your network. Also allowing you to conveniently access the home page of any Axis ThinServer device connected to your network, this freely distributed software is available for download from the Axis Website at [www.axis.com](http://www.axis.com).

### Installing the AXIS IP Installer:

1. Download the latest AXIS IP Installer software onto your desktop and run the *Setup\_IPInstaller.exe* program to start the installation.
2. The **AXIS IP Installer - Setup** dialog is displayed on the screen.
3. Follow the instructions as they appear on the screen.
4. Click **Finish** to complete the installation.

### Setting the IP Address with AXIS IP Installer:

1. Run the **AXIS IP Installer** from the **Start** menu. The **AXIS IP Installer** dialog is displayed on the screen.

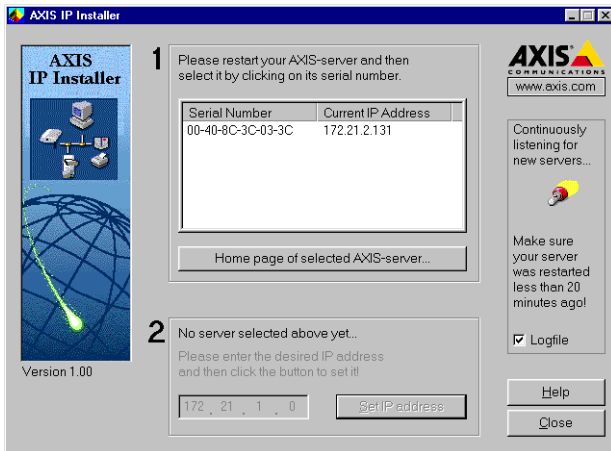

2. Restart your AXIS 2120.
3. Select the serial number of your AXIS 2120 in the list. The serial number is identical to the unit's Ethernet address.
4. Enter the IP address. Click **Set IP address**. The IP address will now be set.
5. To access the home page of the AXIS 2120, click **Home page of selected Axis-server...** You can now configure the AXIS 2120 according to your requirements.
6. Click **OK** to exit the program.

For more help during the installation of the IP address, click **Help** or **F1**.



## Using BOOTP in UNIX

Follow these steps to use the BOOTP method:

1. Append the following entry to your boot table. This is typically done using the file `/etc/bootptab`:

```
<host name>:ht=<hardware type>:vm=<vendor magic>:\  
:ha=<hardware address>:ip=<IP address>:\  
:sm=<subnet mask>:gw=<gateway field>
```

where:

ht = ether  
vm = rfc1048  
ha = The Ethernet address of the AXIS 2120  
ip = The IP address of the AXIS 2120  
sm = The subnet mask  
gw = The default router address

### Example:

```
mycam:ht=ether:vm=rfc1048:\  
:ha=00408c100086:ip=172.21.1.200:\  
:sm=255.255.255.0:gw=172.21.1.1
```

2. If necessary, update the host table and alias name databases for your system.
3. If it is not already running, start the BOOTP daemon. This is typically done using the command `bootpd`.
4. Restart the AXIS 2120 to download the IP address, default router address and subnet mask.

## Mapping a Host Name to the IP Address

If you are using host names, you can also map a unique host name to the IP address. Refer to your system manuals or Network Administrator for instructions on how to perform the name mapping on your particular system.

## Notes for Macintosh Users

The AXIS 2120 supports TCP/IP over Ethernet, or PPP Modem dial-up. You must use TCP/IP on your Macintosh network, as there is no support for AppleTalk.

When using the AXIS 2120 on a Macintosh, please observe the following points:

- The camera has a default IP address of 192.36.253.80.
- Assign a temporary IP address in the same subnet (e.g. 192.36.253.81) to a Mac workstation and then connect to the camera.
- Run the Installation wizard and set the desired IP address for the camera.
- Also reset the correct IP address for the Macintosh workstation.
- Changing the IP address for a Macintosh is simple and there is no need to reboot.

Currently there are limitations in the ActiveX Support in Internet Explorer running on the Macintosh. This results in problems when viewing live moving images. The recommended solution for viewing Axis cameras on the Macintosh is to use Netscape.

---

---

## Installing Your Camera to a Modem

The information in this section describes how to connect the AXIS 2120 to a serial modem for transmitting images over a normal Dial-up connection.

### Before You Begin

Before you can set up and access a modem-connected AXIS 2120 from a browser, you must first create a local connection to it. This connection is only required for the initial set up, and can be created using the network or the supplied Null Modem Cable.

### Using the Network

The easiest and best way to configure the camera for use with a modem is to first install it onto a local network, if one is available. See *Installing Your Camera on a Network*, on page 12 for more information. You can then use the Wizards and Administration tools to configure the modem connection and the application.

### Using the Null Modem Cable

When there is no network available, the alternative is to connect a local computer to the AXIS 2120 using the supplied Null Modem Cable. You then create a Dial-up connection and establish the basic settings, using the Wizards and Administration Tools. See the following pages for more information. This type of connection is only a temporary solution that provides initial access to the camera. Once you have set up the camera for modem access, then all configuration can be done via the modem connection instead and you will not need to use the cable again.

### Important!

Please note that the Null Modem Cable is only intended for the initial configuration of modem applications when there is no Ethernet Network available. It is not possible to use the cable as a serial connection for using the AXIS 2120 as a "web camera".

### Quick Start For Advanced Users:

Follow these abbreviated instructions if you are experienced with Windows Dial-up Networking:

1. Connect the camera to the Ethernet Network if available, and use a browser to open the IP-address you set for your AXIS 2120. Proceed to step 5. If no network is available, use the Null Modem Cable and proceed to step 2.
2. Set up an existing session to 115.200 bps, using the physical COM port to which you have connected your AXIS 2120.
3. Login with the username *root* and the password *pass*. The *Phone Number* and *Modem Type* that you enter are irrelevant at login and you should can use dummy numbers for completing these dialogs.

4. Start your Dial-up Networking session and enter any URL; the AXIS 2120 emulates a DNS server and will respond to this regardless.
5. Start the Installation Wizard and Administration Tools to further configure the product, as described in *Configuring Your Camera*, on page 25.

## Connecting Your Computer Using the Null Modem Cable...

### Important!

- The information and screen examples featured within this section are specific to Windows NT. Although similar to the dial-up procedures in Windows 95, 98, and 2000, small deviations in the dialog instructions for other operating systems should be expected. Refer to your system information for further information on creating a dial-up modem connection if you are using any other operating system.
- Windows dial-up Networking and TCP/IP must be correctly installed prior to commencing with the modem cable connection. Detailed information on how to check this is provided in Windows Help.

Follow the steps below to configure a serial modem connection for your AXIS 2120:

**1** Connect the supplied Null modem cable between the Serial Connector on the AXIS 2120 and the serial port on your computer.

**2** Connect the power supply to the camera server and check that the Power Indicator is lit.

**3** From the Start menu, open the Control Panel and double-click the Modems icon.

**4** If a Standard Modem is already set up and displayed in the Modem Properties dialog (see right) proceed directly to step 8.

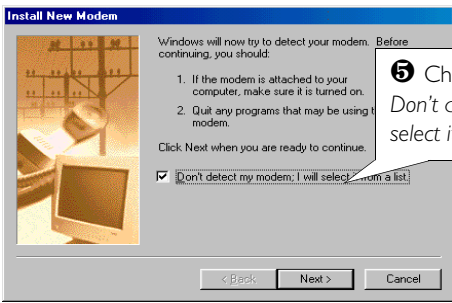
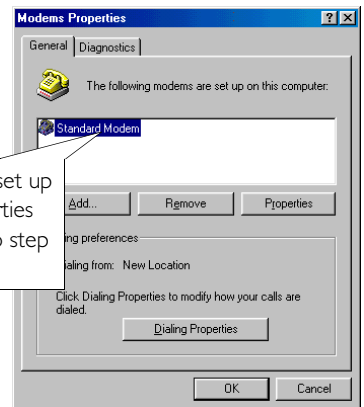

**5** Check the checkbox: *Don't detect my modem, I will select from a list.* Click Next>.

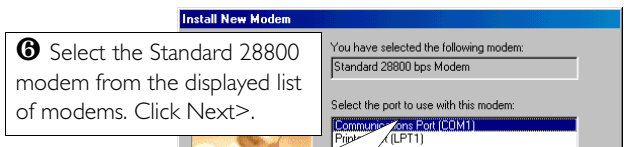

**6** Select the Standard 28800 modem from the displayed list of modems. Click Next>.

**7** Select the serial port to which your AXIS 2120 is now connected via the Null Modem cable. Click Next>.

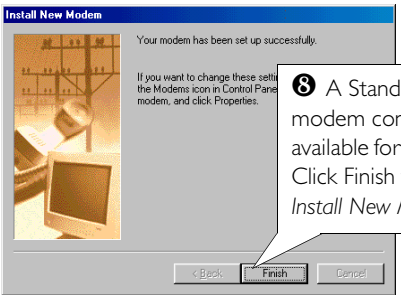

**8** A Standard 28800 modem connection is now available for the AXIS 2120. Click Finish to close the Install New Modem Wizard.

**9** Click the Properties button to finally check that the displayed Communications Port is set correctly; that is, set to the same port as you have connected the AXIS 2120. Click OK.

**10** Click Close.

## Creating a Dial-up Networking Connection...

Follow the steps below to create a dedicated dial-up networking connection to your AXIS 2120:

- 1 Double-click *My Computer* and then double click the *Dial-Up Networking* icon.
- 2 Double-click the *Make New Connection* icon.
- 3 Provide the connection with a name (*AxisCamera* is the name used in the subsequent examples).
- 4 From the drop down dialog, select the *Standard Modem* previously created for the *AXIS 2120* as the selected device. Click *Configure...*
- 5 To significantly improve the performance of your *AXIS 2120* when using the *Null Modem* cable, set the *Maximum Speed* to *115200*.
- 6 Click *OK* to return to the *Make New Connection* dialog. Click *Next>*.
- 7 The telephone numbers requested in the following dialog are not required for use in the logical connection to your camera. To bypass the wizard error correction, simply enter any dummy number into the *Area code*, *Telephone number* and *Country code* fields. Click *Next>*.
- 8 You have now successfully created your dedicated dial-up networking connection for your *AXIS 2120*. Click *Finish*.

The new dial-up network connection is displayed. You are now ready to refine the dial-up networking properties, as described in the next section...

### Refining the Dial-up Networking Properties...

Having created the dial-up connection for your AXIS 2120, follow the steps below to refine the connection properties:

**1** From the dial-up networking dialog, right-click the dedicated dial-up connection previously created for your camera (*AxisCamera* was the connection used in this and previous examples). Select Properties.

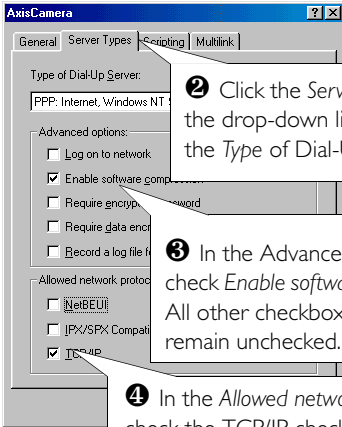

**2** Click the *Server Types* tab. From the drop-down list, select *PPP* as the *Type of Dial-Up Server*.

**3** In the *Advanced options* field, check *Enable software compression*. All other checkboxes should remain unchecked.

**4** In the *Allowed network protocols* field, check the *TCP/IP* checkbox. The *NetBEUI* and *IPX/SPX* checkboxes should remain unchecked.

**5** Click *TCP/IP settings* and then check the *Server assigned IP address*, and *Server assigned name server addresses* radio buttons.

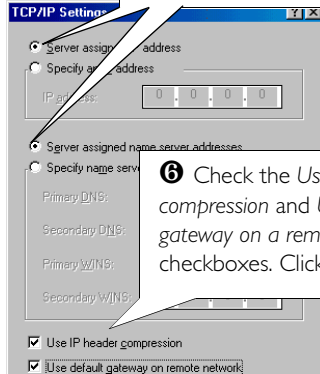

**6** Check the *Use IP header compression* and *Use default gateway on a remote network* checkboxes. Click *OK*.

**7** Click the *Scripting* tag and ensure that the *Start terminal screen minimized* checkbox is checked. Click *OK* to exit *Dial-Up Networking Properties*.

## Initiating the Dial-up Connection...

### Important!

Please ensure that the Null Modem Cable is correctly installed and that the connection properties are correctly configured prior to initiating a Dial-up connection. Instructions on how to do this are provided on the preceding pages of this section.

❶ Double-click *My Computer* and then double-click the *Dial-Up Networking* dialog.

❷ Double-click the dial-up connection icon previously created for your AXIS 2120. *AxisCamera* was used in this and previous examples.

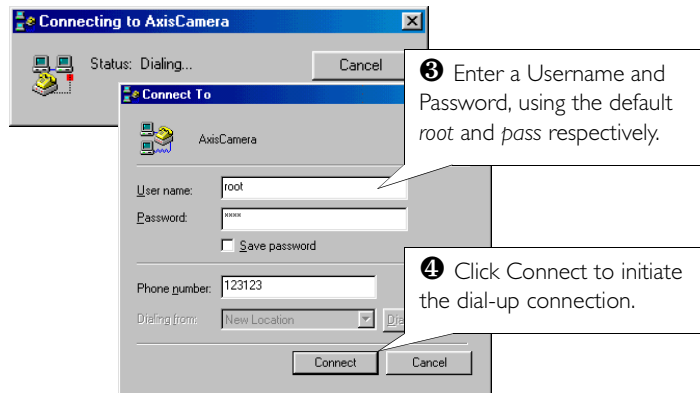

## Verifying the Modem Connection...

Having initiated your dial-up connection as described above, you can quickly verify the integrity of the connection by accessing the AXIS 2120 using a standard browser, such as Netscape or Internet Explorer, as follows:

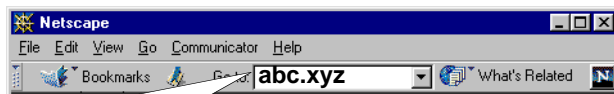

❶ As the AXIS 2120 emulates a DNS server, type in any URL containing a period in the Location/Site field of your browser to display the AXIS 2120 Home Page, as defined below.

❷ Now, configure the unit using the *Installation Wizard* or the *Administration Tools*.



---

---

# Configuring Your Camera

## Important!

Javascript must be enabled in your Web browser for the AXIS 2120 Web-based interface to work.

## Before You Begin

Successful installation of the product is prerequisite to configuring the unit; therefore, it is recommended that you read the following information before commencing with this section:

- *Choosing Your Application*, on page 34, and then...
- *Installing Your Camera on a Network*, on page 12, ...or
- *Installing Your Camera to a Modem*, on page 19.

Having chosen the type of application you want to develop and installed the product accordingly, your AXIS 2120 will now be attached directly to a local area network, **or** connected to a PC using the supplied *Null Modem Cable*. You are now ready to proceed with the unit's configuration.

This section describes how to use the *Wizards* for configuring and integrating the AXIS 2120 into your application environment, and provides a general overview of the Web-based *Administration Tools*.

## Configuration Using the Wizards

For speedy development of your application, the AXIS 2120 supports two easy-to-use Wizards that are recommended for both novice and advanced users alike. Depending upon your choice of application, the *Installation Wizard* and the *Application Wizard* can be run either consecutively, or independently of one another.

## Important!

- When accessing the *Administrator Tools* for the first time during a session, you will be assumed to be the administrator and will be logged in as such, with the username root and default password pass.
- You must change the root password as soon as possible. Until this has been done, the security features in the product be will not be enabled. Furthermore, all Axis products are shipped with the same password by default. For further information, refer to *System Security*, on page 30.
- Prior to accessing the *Installation Wizard* or *Administration Tools* over a network, you must first set the Internet address, as described in *Installing Your Camera on a Network*, on page 12.

## Installation Wizard Overview

The **Installation Wizard** provides a quick and easy way to define the *System*, *Security*, *Image* and *Layout* settings for your application - as described in the *Tools Overview*, on page 29.

### Starting the Installation Wizard

1. With reference to the information provided in the On-line Help , click the **Installation Wizard** from the **AXIS 2120 Home Page** and then follow the Wizard to complete the configuration.
2. Click the **Finish** button to save the defined application settings to the product.

## Application Wizard Overview

The **Application Wizard** can be started from the final page of the **Installation Wizard**, or started independently from the **Administration Tools - Wizards** page. It provides a quick and easy way to define the *Operation* and *Layout* settings for your application - as described in *Tools Overview*, on page 29.

### Starting the Application Wizard

1. With reference to the operation information provided in the On-line Help , click **Continue...** within the **Application Wizard** or click the link from within the **Administration Tools - Wizards Page** to start the Wizard.
2. Click the **Finish** button to save the defined application settings to the camera.

## The Administration Tools

Whether you are viewing images directly over the network or transmitting images over a modem, you can use the Web-based **Administration Tools** for configuring and managing your AXIS 2120 at any time. Used for reviewing and refining your configuration after initially setting up the AXIS 2120 with the **Installation Wizard**, these tools are ideal for more advanced users.

**Note:** On-line help  is stored internally in the AXIS 2120 and is available from most pages within the AXIS 2120 Web interface. Containing comprehensive details on all product parameters and Administration Tools, the on-line help is your first point of reference when configuring and managing the unit, and is particularly useful for resolving any administration queries.

## Accessing the Tools

Follow the instructions below to access the **Administration Tools** using a standard browser:

1. Start the browser and enter the name or Internet address of the AXIS 2120 (or any DNS name if you are accessing the unit via the Null Modem Cable) in the location/address field.

**Example:**

http://172.21.1.200/

2. The AXIS 2120 Home page is now displayed. Click **Administration Tools**.

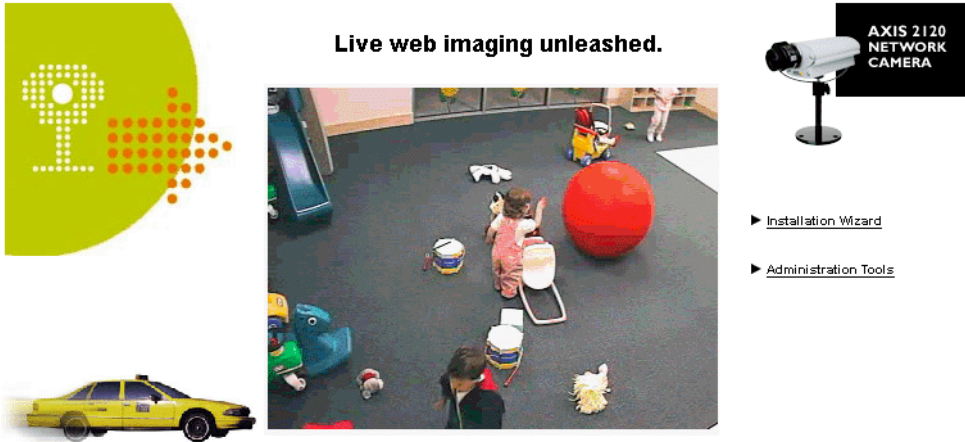

**Note:** When entering these pages for the first time from a browser, you will not be prompted for a username or password. However, to enable the security function you must change the default password (pass) as soon as possible. Log on as root with the default password and then change the password. To complete the operation, close your browser and then reopen it.

3. The **Administration Tools** are now presented as links in the margin of the Administration Page. Simply click the relevant link for the parameters you want to configure. As an *Administrator*, you configure and modify the system directly from this page.

**Settings**

- ▶ Image
- ▶ Network
- ▶ Modem
- ▶ System

**Applications**

- ▶ Operation
- ▶ Motion detection
- ▶ Layout

**Wizards**

- ▶ Installation
- ▶ Application

**Support**

- ▶ Help

- ▶ Home

**Administration Tools****AXIS 2120  
NETWORK  
CAMERA**

After initially setting up the AXIS 2120 with the available Wizards, you use these Web-based Administration Tools for configuring and managing your AXIS 2120.

Click the links in the left-hand margin to navigate your way around the Administration Tools and conveniently configure and manage the product in your Web browser.

**Note:** Operational information for each supported tool is available from the online help.

## Tools Overview

The table below provides a one-stop overview of the **Administration Tools**:

Settings	Tool Description
Image	Focus the camera using the Focus Assistant, adjust the Auto Iris settings, and define image attributes for your AXIS 2120.
Network	Configure the TCP/IP and SMTP E-mail network settings.
Modem	Configure the communication settings for the <i>Dial-up Modem Connection</i> to your ISP or remote Web server.
System	Set the product Date and Time, create and delete Users and passwords, and change the Administrator's password.  By default, the AXIS 2120 supports anonymous user access, which means that anybody on the Internet/intranet has access to the video images from a Web browser. To restrict open access, simply register a single authorized user.
Applications	Tool Description
Operation	Choose to run your AXIS 2120 in Sequential or Alarm Mode; determine when and how often images are taken using the <i>Scheduler</i> ; and define when the images are uploaded to an ISP, or target FTP/Web server.
Motion Detection	Enable in-picture motion detection and trigger an immediate alarm whenever significant movement occurs in the picture area. Create a single motion detection window for the whole image area, or create up to three discrete drag-and-drop windows and restrict alarms to movement in specific areas. Each motion detection window is assigned with a unique name, and a set of profile sliders that allow you to set individual alarm thresholds for the Size, History, and Sensitivity parameters.  A Motion Indicator is also included to provide an immediate visual display of actual detected motion against the defined alarm thresholds that are established for the highlighted window.
Layout	Determine the Layout for the Web page in which your images will appear. Customize the page to your own design and include your own logos, links and title texts, and enable or disable specific function buttons.
Wizards	Tool Description
Installation	The Installation Wizard helps you quickly get the product up and running. Recommended for use by both novices and experienced users.
Application	This Wizard will guide you through the process of setting up your application.
Support	Tool Description
General	Displays various useful information about how and where to get help.
Release Notes	View the product <i>Release Notes</i> , the <i>Parameter List</i> , and/or initiate a <i>Restart</i> of the unit.
Parameters	Displays the complete list of settings currently valid in the unit.
Log File	Displays the log file showing all of the commands executed since the last restart.
Restart/ Reset	Provides commands for restarting the unit and for resetting to the factory default settings.
Home	Links directly to the Home Page of your application.
About	Displays information about the development of this product.
Help	Starts the product's on-line help
Home	Opens the product's home page.

## System Security

To prevent any unauthorized use of the camera, the AXIS 2120 supports multi-user password protection and access is restricted to defined *users only*. The system *Administrator(s)* has exclusive access to the product's *Administration Tools* and can determine the registration and access rights for all *users*.

- Note:**
- When accessing the Administrator Tools for the first time during a session, you will be assumed to be the administrator and will be logged in as such, with the username *root* and default password *pass*.
  - The root password must, however, be changed as soon as possible. Until this has been done, the security features in the product will not be enabled. Furthermore, all Axis products are shipped with the same password by default. Close and restart your browser to complete the operation.

### User Access Rights

As an *Administrator*, click **Users** to perform any of the following tasks:

- define or edit the **administrator (*root*) password**
- define, add and delete **user names and passwords**
- assign individual access rights for selected users, where each user is awarded one or all of the following levels of access:
  - **Admin:** a user granted with *Admin rights* has exclusive access to the product *Administration Tools* and can consequently determine the registration of all *users*.
  - **Dial-in:** provides the user with dial-in modem access only to the AXIS 2120.
  - **View:** provides the lowest level of access, which allows the user to view the images only. Specifying at least one such user will disallow all other anonymous access.

### Important!

By default, the AXIS 2120 supports anonymous user access, which means that anybody on the Internet/intranet has access to the video images from a Web browser.

To restrict open access, simply register a single authorized user. This effectively disables the anonymous user service and restricts camera access to specified users. If the anonymous user service is satisfactory for your application, simply do not add any users. The Administrator's own settings are enough to provide anonymous viewing access.

## Motion Detection

The AXIS 2120 includes in-image motion detection that comprises multi-window support for up to three motion detection windows in the target image area.

Use the motion detection feature to generate an alarm whenever movement occurs in the image area. You can create a single window for monitoring the whole surveillance scene, or create three smaller windows for targeting specific areas within the image area. All movement outside the defined motion detection window is ignored.

You can create up to three motion detection windows, and move, resize, or delete any window at any time. Furthermore, the behavior for each motion detection window can be defined by adjusting the **Size**, **History**, and **Sensitivity** *profile sliders* for each window. The user interface for this function is very easy to use!



**Settings**

- ▶ Image
- ▶ Network
- ▶ Modem
- ▶ System

**Applications**

- ▶ Operation
- ▶ **Motion detection**
- General
- ▶ Layout

**Wizards**

- ▶ Installation
- ▶ Application

▶ Support

▶ Help

▶ Home

### Motion Detection

Set the Motion Detection to detect movements in a full image or specify up to three areas with different parameters. Detected motion will generate an alarm that is handled as an ordinary alarm by the camera.

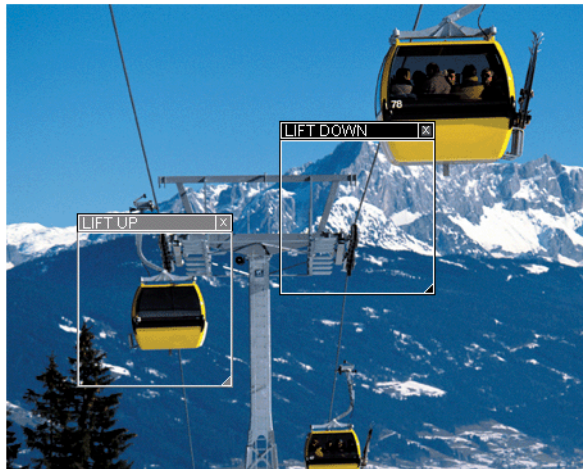

Window Name:

LIFT DOWN

0 % 0 % 0 %



Size History Sensitiv

Save

Test



Motion Indicatc

### Important!

The video motion detection algorithm in the AXIS 2120 is specifically designed for non-critical remote monitoring applications, and consequently Axis advises against using this product for critical surveillance usage - where reliable motion detection must be assured at all times.

Axis does not accept liability for any incidents of unwarranted triggering or failure of the product motion detection function - spurious, occasional, or otherwise.

## Creating a Motion Detection Window

Follow the instructions below to create a motion detection window within the image area:

1. Click the **New** button to open a standard-sized window; or click and drag the mouse from within the image area to create a motion detection window of any size.
2. Drag and drop the new window to any area you wish to monitor. By dragging the bottom-right corner of the window you can also resize the motion detection window, if desired.
3. A **Name** field, complete with the respective **Size**, **History**, and **Sensitivity** *profile sliders* are now displayed for the new motion detection window you have created. In the **Name** field, enter a suitable name for the motion detection window, and set the **Size**, **History**, and **Sensitivity** profile sliders accordingly for your image area. A full description of each *profile slider* is provided in the table below:

Profile Slider Parameter	Description
Size	<p>Defines how large a moving object must be to trigger the motion detection - relative to the size of the defined motion detection window. For example; when monitoring a landscape, setting the size parameter to small might possibly trigger the motion detection each time a bird flies through the motion detection window.</p> <p>The 'size' profile slider is used to determine the minimum size of the triggering object within the motion detection window.</p>
History	<p>Defines the elapsed time duration between the comparable reference and the current images; i.e. should your AXIS 2120 compare the latest image with the one taken previously (Low level), or against one taken over an hour ago (High level)?</p> <p>A High level setting causes the reference image to be updated very infrequently; consequently, any significant change in the target image will initiate an alarm that is active for a long period of time. A Low level setting causes the reference image to be updated very frequently; consequently, any significant object in the target image area will be active for only a very short period, before being seen as identical to the updated reference image.</p> <p>This parameter is useful for 24 hour monitoring when night turns to day, and other occasions when you want slight deviations in the motion detection window area to be tolerated without initiating alarms.</p>
Sensitivity	<p>Defines how subtle the change of color, or nuance, needs to be before a motion detection alarm is triggered.</p> <p>Ordinary colored objects on ordinary backgrounds trigger the motion detection when this parameter is set to High level. When set to a Low level, only very bright objects on a dark background will trigger the motion detection.</p>

4. Click the **Save** button to register the motion detection window settings. The **Motion Indicator** is now active, displaying the current motion level with the threshold value for alarm settings represented by a *black* colored **delimiter bar**.
5. Having saved a new motion detection window, any detected motion is then displayed within the Motion Indicator. However, an alarm is only generated if the motion exceeds the tolerance defined by the delimiter bar. The Motion Indicator displays *red* whenever enough motion occurs to trigger an alarm.



## Deleting a Motion Detection Window

To delete a window, simply select the motion detection window you wish to delete and press the **Delete** button.

## Reinstating the Factory Default Settings

In certain circumstances, it may be necessary to reinstate the **Factory Default** settings for your AXIS 2120. This is performed by clicking the appropriate button in the **Administration Tools**, or by pressing the **Control Button**. Follow the instructions below to reinstate the product factory default settings using the Control button:

1. Switch off the AXIS 2120 by disconnecting the power cable.
2. Press and keep the Control Button pressed, and then reconnect the power supply cable.
3. Keep the Control Button pressed until the Status Indicator displays *yellow* (note that this may take up to 15 seconds), then release the button. When the Status Indicator displays *green* (which can take up to 1 minute) the AXIS 2120 will then have been reset to the original factory default settings.

- Notes:**
- Reinstating the factory default settings will cause all parameters (including the IP address) to be reset.
  - Refer to *Installing Your Camera on a Network*, on page 12, or *Alternative Methods of Assigning the IP Address*, on page 15, for information on how to set the IP address in the product.

---

---

## Choosing Your Application

The AXIS 2120 can be used in a wide variety of applications and installs directly onto an Ethernet network, or it can be used with a V.90-compatible modem. Requiring no additional software on your viewing desktop, it is a completely self contained unit that delivers crisp, live images to your preferred browser. Using the Web-based *Administration Tools* and easy-to-use *Wizards*, you can develop your application quickly and easily.

Not to be regarded as a comprehensive catalog of possible user applications, this section describes several typical applications, and includes other reference information to help prepare you for the installation and configuration of the unit.

**Notes:** • Although most V.90-compatible modems are known to work well with the AXIS 2120, Axis does not guarantee that the product will work with all modems conforming, or otherwise, to the same standard.

## Networking Applications

If you have access to an Ethernet connection at your chosen point of installation, all you need to do is attach the AXIS 2120 to your LAN/WAN and set the IP Address. Then you are ready to view images from any desktop over your network.

However, the AXIS 2120 offers more than just convenient access to live images over the network. Using the available *Wizards* to guide you through the process, you can quickly configure your product for a variety of exciting applications, including:

- Viewing images in a custom-designed Web page.
- Uploading images to a remote FTP server on a LAN/WAN network to accommodate a large audience where a high volume of Web page hits is anticipated.
- Motion detection or external alarm device triggering - with uploading of pre and/or post alarm images to a target FTP server, when in-image motion, external alarms, or time-based events occur. You can also optionally send e-mail alerts containing a single image, or a Web link to a pre/post alarm image sequence stream saved to the target FTP server.

**Note:** You can access live images from any desktop browser on your network as soon as the AXIS 2120 is physically installed on your network. The installer of the camera uses the available *Wizards* to configure the chosen application. Advanced users can then use the Web-based *Administration Tools* for refining the application once the basic configuration has been established with the *Wizards*.

## Picture frequency for Networking Applications

When used in a TCP/IP networking environment, the AXIS 2120 delivers up to 25/30 (PAL/NTSC) images/second; where the actual image frequency is typically limited by:

- your computer and browser
- the chosen image resolution and compression
- the lighting conditions at the point of installation
- available network bandwidth
- the complexity of detail and color variation within the image

### Important!

60Hz and 50Hz variants of the AXIS 2120 are available to accommodate the different power supply frequencies found in the USA and Europe.

The 60Hz variant delivers a resolution of 525 lines at 60 half-frames per second and is suitable for use in the United States; whereas, the 50Hz variant delivers 625 lines at 50 half-frames per second and is appropriate for use in Europe.

## Image Compression Ratios

Although the file size of a JPEG-compressed image depends upon the actual content of the image, images containing a lot of detail generally generate larger files. Image quality is largely controlled by the level of compression; where high compression yields small files, and low compression maintains higher image quality at the expense of larger files. The table below is derived from real-life tests, and defines the average file sizes for each supported image resolution:

60Hz (NTSC Countries)			50 Hz (PAL Countries)		
Resolution	Filesize (kb)	Max fps*	Resolution	Filesize (kb)	Max fps*
4CIF (704 x 480) **	7 - 150	10	4CIF (704 x 576) **	8.5 - 180	8
CIF (352 x 240)	1.4 - 40	30	CIF (352 x 288)	1.7 - 50	25

\* Maximum performance for a single viewing client.

\*\* Interlaced image

**Note:** Using a modern computer will avoid introducing any unnecessary constraints on the imaging frequency.

## Viewing Images in a Custom-designed Web Page

Often used as an attraction for enhancing a Web site with live images, this type of application represents the most basic form of network camera configuration. It is ideally suited for *occasionally-visited* sites on both large corporate networks and on SOHO (Small-Office Home-Office) applications, where a small network is installed and maintained.

If you anticipate a large audience for your images, you should consider configuring your product to upload images to an FTP server, as described in *Sequentially Uploading Images to a Remote FTP Server* on page 37.

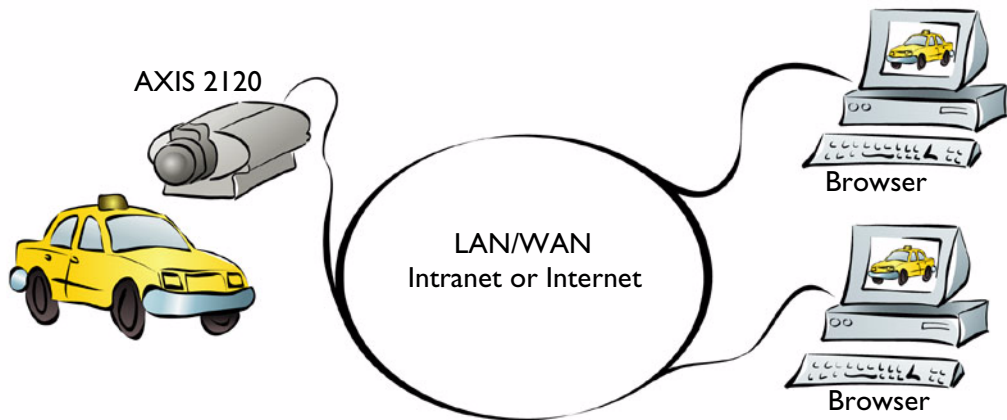

Simply install the AXIS 2120 directly on your local Ethernet network and complete the *Installation Wizard* to immediately view live video images in your own custom-designed Web page. The Wizard not only helps you define the image format and personalized characteristics of your Web page *Layout*, but also allows you to determine how accessible the product is over your intranet or Internet network. You decide in just a few simple steps.

### Installation and Configuration Overview

Configure your AXIS 2120 for viewing images over a network as follows:

1. Connect the AXIS 2120 to your local network. Refer to *Installing Your Camera on a Network* on page 12.
2. Open the product **Home Page** in your browser and start the **Installation Wizard**; complete the Wizard to establish the standard *Security, Date and Time, Image General Layout* and *TCP/IP Network* settings - selecting **network** as your chosen method of connection in the **Modem or Network** dialog. Refer to *Configuring Your Camera* on page 25.
3. The application setup is now complete. Having completed the Wizard, you should now verify the installation by checking that you have full access to both the images and the product Web pages in your browser.

**Note:** Although custom HTML code is not supported by Axis, advanced users can optionally write their own individual pages, as described in *Appendix E - Custom Web Pages*.

## Sequentially Uploading Images to a Remote FTP Server

Ideal for any *busy* Web site where a large audience is expected, this application uploads images to a designated FTP server on your network to provide image access to an unlimited amount of viewing clients over your intranet or the Internet

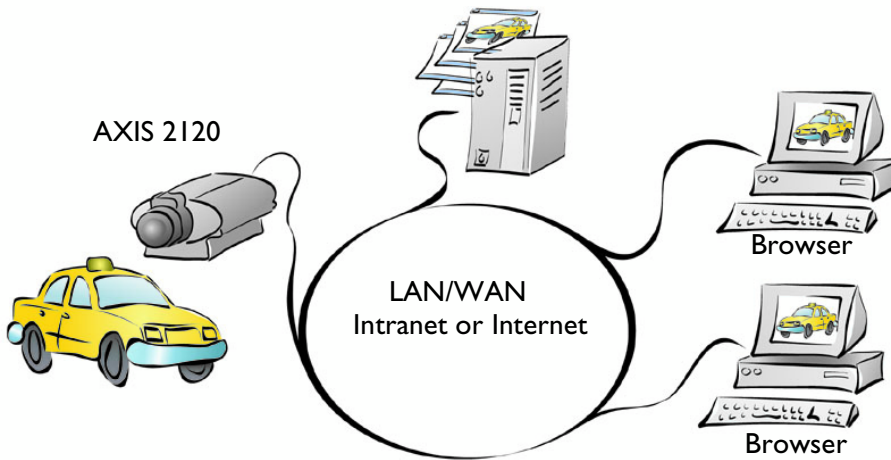

Simply install the AXIS 2120 directly on your local Ethernet network and complete the **Installation** and **Application Wizards** to develop an *active* application that will upload images to a designated FTP server - as a *sequential* stream that is unlimited, or at specified time periods. Then organize the times and the frequency at which your images are taken and uploaded to the target FTP server.

### Installation and Configuration Overview

Configure the AXIS 2120 to actively upload images to an FTP server as follows:

1. Connect the AXIS 2120 to your local network. Refer to *Installing Your Camera on a Network* on page 12.
2. Open the product **Home Page** in your browser and start the **Installation Wizard**. Complete the Wizard to establish the standard *Security, Date and Time, Image General Layout* and *TCP/IP Network* settings - selecting **network** as your chosen method of connection in the **Modem or Network** dialog. Refer to *Configuring Your Camera* on page 25.
3. Continue the configuration of your product using the **Application Wizard** to define the target FTP server and your preferred mode of operation - choosing **Sequential** mode to create your active application.
4. Having completed the Wizard, you should now verify the configuration by accessing the images stored on the FTP sever from your browser.

## Uploading Pre and/or Post Alarm Images to a Remote FTP server

The AXIS 2120 is an ideal solution for a wide variety of remote monitoring applications. By creating windows for in-image motion detection, or by connecting an external alarm device to the I/O connector, you can quickly configure the product to upload single images, or send pre/post alarm image sequences to an FTP server when a time or alarm-based event occurs.

Using the available *Wizards*, you organize the times and frequency at which images are taken and uploaded to the target FTP server, and optionally arrange for e-mail alerts containing single images, or Web references to recorded image sequences.

### Installation and Configuration Overview

Configure the AXIS 2120 to upload Pre and/or Post Alarm images as follows:

1. Connect the AXIS 2120 to your local network. Refer to *Installing Your Camera on a Network* on page 12.
2. Open the product **Home Page** in your browser and start the **Installation Wizard**. Complete the Wizard to establish the standard *Security, Date and Time, Image General Layout* and *TCP/IP Network* settings - selecting **network** as your chosen method of connection in the **Modem or Network** dialog. Refer to *Configuring Your Camera* on page 25.
3. Continue the configuration of your product using the **Application Wizard** to define the target FTP server and define your preferred mode of operation - choosing **Alarm Mode** to upload single images, or pre/post alarm image sequences, when a defined alarm or time-based event occurs.
4. Having completed the Wizard, you should now verify the configuration by triggering the defined alarm event and then viewing the uploaded images in your browser.

**Note:** For full details on how to create and use motion detection windows, see *Motion Detection* on page 31.

## Modem Applications

If a local network connection is not available at your chosen point of installation, you can alternatively connect your AXIS 2120 to a V.90-compatible modem and quickly configure any number of exciting applications using the Wizards; including:

- Viewing images in a fully custom-designed Web page over a Dial-up modem connection.
- Sequentially uploading images to an ISP (Internet Service Provider) over a dial-up modem connection and publishing images to the whole Internet community.
- Uploading single or pre/post alarm image sequences to your ISP over a dial-up modem connection, when an alarm or time-based event occurs; and optionally, sending e-mail alerts containing single images or Web links to pre/post alarm images stored by your ISP.

### Important!

- Although the AXIS 2120 is compatible with most V.90-compliant modems, Axis does not undertake any responsibility for V.90 modems that fail to work with the product.
- When the AXIS 2120 is dialing out it will obviously not be possible to dial-in to it. If you configure an interval during which the camera will not be dialing out, this will allow you to dial-in and make any necessary changes etc.

## Configuration

All modem applications must initially be configured from a browser on a local computer. If available you should always use an Ethernet network for this purpose, even if the actual application will be using a modem. If there is no network available, you can instead use the supplied *Null Modem Cable* to create a direct connection to the AXIS 2120 from the computer. This direct connection is only intended as an alternative for the initial configuration of the modem application when there is no network available. The Null Modem Cable should not be used for any other purpose.

**Note:** Once the Dial-up modem connection has been created and the AXIS 2120 is physically connected to the modem, you can then dial-up your AXIS 2120 in exactly the same way as you would to your ISP. The installer of the camera uses the *Installation* and *Application Wizards* to establish the basic parameters for your application, and advanced users can then use the *Administration Tools* to refine the application.

## Picture Frequency for Modem Applications

When used with a modem, the speed of your communications link will normally determine the image frequency in your browser. A standard image is normally transmitted in 2-5 seconds, although optimal image frequency is achieved by buffering the video stream into internal memory before uploading the recorded images to your ISP or Web server. This is the ideal solution for remote applications connected to external security devices and which require a good flow of images from alarm events.

### Proprietary ISP Dial-up Protocols

If your ISP requires you to install special software before initiating a Dial-up connection, it is likely that your ISP is using proprietary protocols incompatible with the standard-based AXIS 2120. In these circumstances, Axis recommends that you ask your ISP for an alternative dial-up service that allows for standard dial-up networking, or ask them to provide a standard Linux dial-up connection. Axis does not guarantee the compatibility of this product with any ISP requiring the use of proprietary or non-standard software as a pre-requisite for Dial-up connections.

### Remote Imaging in a Custom-designed Web Page

The AXIS 2120 can be configured as a standalone application that is remote from any network. Ideal for remote monitoring, home security, and process control applications, you can quickly configure the AXIS 2120 for direct connection to a serial modem. Use this application to view remote images from anywhere - from the comfort of your home, or the convenience of your office.

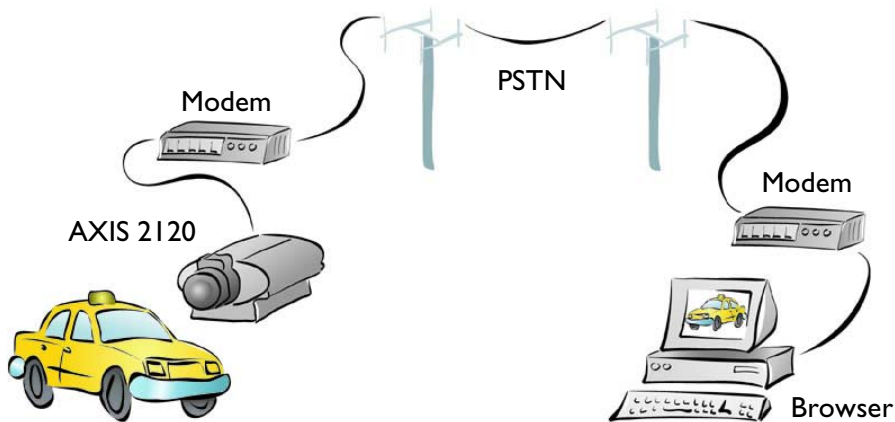

Once the dial-up connection for your AXIS 2120 is established, the product plugs directly into a serial modem to provide immediate access to live video images in your own custom-designed Web page. You access the images and the product Web pages in exactly the same way as you would when connected to your ISP.



## Installation and Configuration Overview

Configure the AXIS 2120 for viewing images over a remote dial-up modem connection as follows:

1. Connect the AXIS 2120 to the network if available. Otherwise, use the supplied Null Modem Cable. Connect a computer and initiate a dial-up connection to the camera. For this and general information on the dial-up connection, refer to *Installing Your Camera to a Modem* on page 19.
2. Create a dedicated dial-up Connection.
3. Refine the dial-up parameters.
4. Initiate the dial-up connection.
5. Referring to *Configuring Your Camera* on page 25, open the product **Home Page** in your browser and start the **Installation Wizard**. Complete the Wizard to establish the standard *Security, Date and Time, Image General Layout and Modem* settings - selecting **modem** as your chosen method of connection.
6. Disconnect the AXIS 2120 from the network or Null Modem Cable and connect it directly to the modem.
7. The application setup is complete. You should now verify the installation by remotely accessing the AXIS 2120 Web pages from your browser via the connected modem.

**Note:** Except for when the AXIS 2120 is dialing-out, you can refine or amend the product configuration at any time using a remote Dial-up connection - or a local computer connected via the supplied Null Modem Cable.

## Uploading Images to Your Internet Service Provider

Perfect for Web attractions, remote monitoring and process control applications; the AXIS 2120 can be quickly configured to dial-out from any remote location and transmit live images to an Internet Service Provider - where your images can then be accessible to several specific users, or the whole Internet community! You can select any of the supported *Public ISPs* supported in the *Application Wizard*, or specify a *Public* or *Private ISP* of your own choosing.

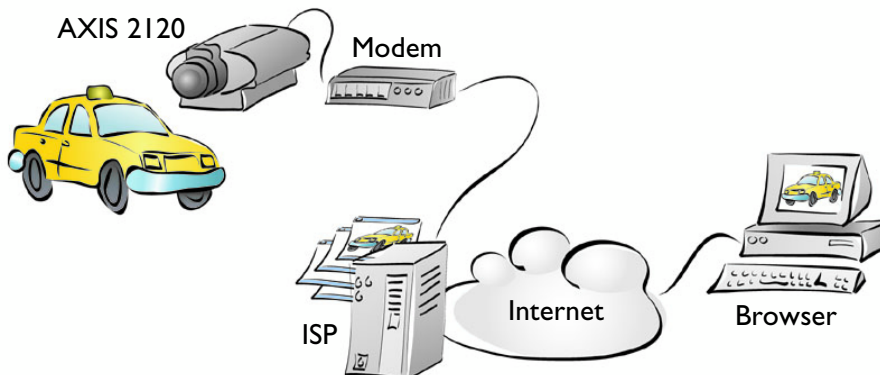

Having established the Dial-up connection for your AXIS 2120 using the **Installation Wizard**, continue with your configuration using the **Application Wizard** to develop an *active* application, which uploads live images to a designated ISP over standard phone lines. You can arrange for image files to be transmitted as a *sequential* stream, or only at specified time periods; and you can set the times and frequency at which images are taken and uploaded to your ISP.

## Installation and Configuration Overview

Configure the AXIS 2120 to upload images to an Internet Service Provider, as follows:

1. Connect the AXIS 2120 to the network if available. Otherwise, use the supplied Null Modem Cable. Connect a computer and initiate a dial-up connection to the camera. For this and general information on the dial-up connection, refer to *Installing Your Camera to a Modem* on page 19.
2. Create a dedicated dial-up connection.
3. Refine the dial-up parameters.
4. Initiate the dial-up connection.
5. Referring to *Configuring Your Camera* on page 25, open the product **Home Page** in your browser and start the **Installation Wizard**. Complete the Wizard to establish the standard *Security, Date and Time, Image General Layout* and *Modem* settings - selecting **modem** as your chosen method of connection.
6. Continue the configuration using the **Application Wizard** to define your preferred ISP and mode of operation - choosing **Sequential** mode to upload an image sequence that is unlimited or restricted between specified time periods but independent of any alarm event.
7. Disconnect the AXIS 2120 from the network or Null Modem Cable and connect it directly to the modem.
8. The application setup is complete. You should now verify the installation by remotely accessing the images that are now stored by your ISP.

**Note:** Except for when the AXIS 2120 is dialing-out, you can refine or amend the product configuration at any time using a remote dial-up connection or a local computer connected via the supplied Null Modem Cable.

## Uploading Pre/Post Alarm Images to Your Internet Service Provider

Perfect as a remote imaging tool, the AXIS 2120 not only transmits live video streams over a standard Dial-up connection, but also supports in-image motion detection and the connection of a wide variety of standard external alarm devices.

Using the **Application Wizard**, the AXIS 2120 is quickly configured for uploading single or pre/post alarm images to an ISP under alarm conditions. You define the times and the frequency at which images are taken and uploaded to the ISP, and optionally arrange for e-mail alerts containing single images, or Web references to image streams stored with your ISP.

## Installation and Configuration Overview

Configure the AXIS 2120 to upload images to an Internet Service Provider in Alarm Mode, as follows:

1. Connect the AXIS 2120 to the network if available. Otherwise, use the supplied Null Modem Cable. Connect a computer and initiate a dial-up connection to the AXIS 2120. For this and general information on the dial-up connection, refer to *Installing Your Camera to a Modem* on page 19.
2. Create a dedicated dial-up connection.
3. Refine the dial-up parameters.
4. Initiate the dial-up connection.
5. Referring to *Configuring Your Camera* on page 25, open the product **Home Page** in your browser and start the **Installation Wizard**. Complete the Wizard to establish the standard *Security, Date and Time, Image General Layout* and *Modem* settings - selecting **modem** as your chosen method of connection.
6. Continue the configuration using the **Application Wizard** to define your preferred ISP and mode of operation: choose **Alarm Mode** to upload single images, or upload pre/post alarm image sequences when in-image motion is detected or when a defined alarm or time based event occurs. For information on how to create and use motion detection windows, see *Motion Detection* on page 31.
7. Disconnect the AXIS 2120 from the network or Null Modem Cable and connect it directly to the modem.
8. The application setup is complete. You should now verify the configuration by triggering the defined alarm event and then viewing the resultant images uploaded to your ISP.

**Note:** Except for when the AXIS 2120 is dialing-out, you can refine or amend the product configuration at any time using a remote dial-up connection or a local computer connected via the supplied Null Modem Cable.

## Adjusting the Camera Focus

The AXIS 2120 has a varifocal DC Iris lens that automatically regulates the amount of light entering the camera, to provide a wide-angle zoom with a minimal amount of distortion. Complete with a standard CS-mount, this supplied lens can also be replaced by any other lens conforming to the same standard.

### Direct Focusing in Your Browser

Supporting rotational focus control, the AXIS 2120 can be targeted for different applications. With your video feed on display on a local desktop, simply adjust the camera focus ring until you are satisfied with the focus.

However, for remote installations - where you cannot view your video images directly from your chosen point of installation - you can achieve a good level of camera focus by using the **Focus Assistant**, described later in this section.

- Notes:**
- The text information printed on the lens assembly will clearly define the focusing polarity (F,  $\infty$ , and N) for the focus ring supplied with your unit. The camera focus is adjusted for either Far-focus (F,  $\infty$ ) or Near-focus (N) by rotating the focus ring in the appropriate direction.
  - The lens rotates on a screw fitting and can be completely removed. If you need to remove the lens, take care not to let any dust enter the lens or the camera window as this can adversely affect the quality of your live images.

**Important!**  
The lens assembly illustrated below is NOT typical for all lens types.

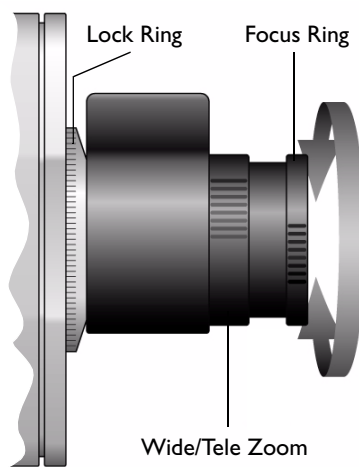

## Using the The Focus Assistant

### Important!

As an alternative to the procedures described here, you can also enable and use the Focus Assistant directly from the Administration Tools. For more information on this, please refer to the on-line help.

Enabled manually using the **Control Button** (or via the product configuration Web pages), the **Focus Assistant** works in conjunction with the **Status Indicator** to provide an onboard visual display for focusing your camera. With the **Focus Assistant** enabled, the **Status Indicator** displays **Green** when the camera is focused - which means that you can conveniently focus the AXIS 2120 without having to monitor the images in a desktop browser.

### Focusing Quality

The table below shows the full range of colors displayed by the **Status Indicator** when the **Focus Assistant** is enabled; where each color represents a predefined level of focus:

Color	Level of Focus (%)	Focus Quality
Red	0 - 60	Poor
Yellow	60 - 80	Reasonable
Green	80 - 100	Good

### Plane of Focus

The AXIS 2120 has rotational focus control that allows the focal length of the lens to be adjusted manually. Dependent upon the chosen physical location for your camera, it is likely that several planes of focus will exist throughout the full focusing depth of the unit. Consequently, the **Status Indicator** is likely to display green - indicating a *good* level of focus - several times throughout the full travel of the lens assembly.

## Focusing Procedure

### Before you begin:

For the focusing algorithm to work efficiently, always ensure that there is minimal movement within the camera's field of view when focusing your camera, as described below.

With reference to the accompanying illustrations, follow the instructions below to achieve a good basic level of focus under stable conditions:

### Important!

Do not press the Control Button for at least 10 seconds after powering up the unit as this will cause the AXIS 2120 to return to the factory default settings.

1. Power up the AXIS 2120 and then wait at least 10 seconds.
2. Turn the lens to its extreme Far-focus (F,  $\infty$ ) position.
3. Enable the Focus Assistant: Using a suitably pointed object, press and continue to hold the **Control Button** - until the **Status Indicator** flashes *Yellow*.

The **Focus Assistant** is now enabled with the **Status Indicator** set to **Focus Mode**; the AXIS 2120 now initiates a focusing algorithm to regularly calculate the quality of focus.

4. In order for the **Focus Assistant** to access the full focusing range for your application environment, now turn the lens to its extreme Near-focus (N) position.
5. Finally, turn the lens slowly towards the Far-focus (F,  $\infty$ ) position - until the **Status Indicator** displays *Green*; that is, until a *Good* level of focus is achieved.

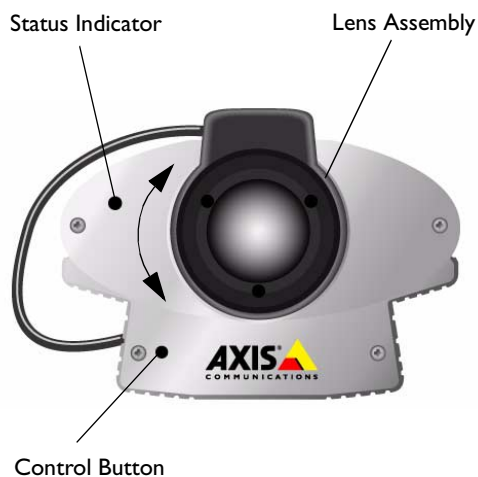

- Notes:**
- A Good level of focus is normally achievable throughout several planes within the focusing range of the camera.
  - The Status Indicator displays Green to indicate a Good level of focus at 80% of optimum focus.
  - Since optimum focusing is dependent upon the camera's field of view, it is important to scan the focusing plane from the closest to the furthest perspectives before attempting any fine-tuning.

- Return to your browser and review the picture quality. Repeat steps 4 & 5 only if you consider the focal distance too distant - until you are satisfied with both the focal-distance and focus-quality.
- To exit the **Focus Assistant**: press and hold the **Control button** - until the **Status Indicator** flashes *Yellow*. The **Status Indicator** displays *Green* when the **Focus Assistant** is closed.

## Replacing the Lens

Since the AXIS 2120 is designed with a CS-mount, the lens supplied with your product can be replaced with any standard C or CS lens typically used within the surveillance industry.

**Note:** Although the lens supplied with your product can be directly replaced with any CS-type lens, a C-type lens must be installed with an adaptor for it to work with your AXIS 2120. An adaptor effectively moves the lens 5mm farther from the camera.

Follow the instructions below to replace the supplied DC-Iris lens with any C or CS type lens:

- Unscrew the AXIS 2120 lens.
- C-lens only:* Attach the *new lens* to a *C-CS Adapter*.
- Screw the *new lens* onto the AXIS 2120. If applicable, adjust the iris according to the prevailing light conditions.
- Referring to *Focusing Procedure* on page 46, adjust the camera focus.
- Hit Refresh in your browser and monitor the results from the product **Home Page**.

## Adjusting the DC-Iris Settings

If you choose to replace the lens supplied with your AXIS 2120 with something more specific to your end-user application, the DC-Iris settings must be adjusted from their standard factory default. In this case, you will need to modify the **Exposure Control** and other related settings for your camera from the **Image-Advanced** page.

Use the information presented in the following tables to choose the appropriate settings for your lens type.

### Caution!

Exposing your camera to bright sunlight may cause permanent damage to the CCD if you:

- install and use a non-DC Iris lens with the product, or
- select anything other than *DC-Iris* in the *Exposure Control* settings of the *Image - Advanced* page.

Axis consequently advises extreme caution when changing the lens and/or when using the *Image - Advanced* settings, as failure to do so may invalidate your product warranty.

## Exposure Control Overview

The table below provides a summary of the Exposure Control settings in the **Image - Advanced** page. Select the parameters appropriate to your lens type and product application:

Lens Options	Description
DC Iris	The AXIS 2120 is supplied with a DC Iris lens as standard; consequently, the DC Iris setting is the standard factory default setting within the Image-Advanced page. It allows the user to manually specify the exposure, shutter speed, gain, and ALC levels.
Non DC Iris - Manual	Choose this setting if you have fitted a non-DC Iris lens to your AXIS 2120, but wish to adjust the shutter speed and gain <i>manually</i> .
Non DC Iris - Shutter	Choose this setting if you have fitted a non-DC Iris lens to your AXIS 2120, but wish to adjust the shutter speed, <i>manually</i> .
Non DC Iris - Auto	Choose this setting if you have fitted a non-DC Iris lens to your AXIS 2120 and would like the shutter speed and gain to be adjusted <i>automatically</i> .

## Other Advanced Parameters

Lens Options	Description
Shutter Speed	Derived from the shutter speed on a normal camera, this parameter defines the exposure period for each image. Use a high shutter speed only if your image subject is expected to be moving quickly; otherwise, a slower speed will normally suffice.
Sharpness	Defines a level of differentiation between light and dark areas in the image. Corresponding higher levels of sharpness provide for sharper images, but also cause the image compression to be more complex. Consequently, the file size of a sharp image can be significantly greater than for an image that is less sharp.
Gain	Adjust the gain to suit the average level of light at your point of installation. The AXIS 2120 should be set to a corresponding higher level of <i>Gain</i> if your camera is normally monitoring an area at night, or is sited in a dark room or cupboard.
ALC Level	This defines how acutely the lens reacts to a single light source within the image. For example, with the ALC level set a higher level, the headlights from a car will generally cause the calculated average level of light to increase, and subsequently result in a compensated image that is usually much darker.  Adjusting the ALC to a corresponding lower level reduces the sensitivity of the lens to single light sources within the image.



## Adjusting the Back Focus

Your AXIS 2120 is supplied with the back focus roughly set to accommodate a reasonable level of focus throughout the complete focusing range. However, if you are using a lens other than that supplied with your product - or you are dissatisfied with the quality of focusing at a specific plane (or at several planes) within the focusing range, you may need to make some fine adjustments to the back focusing of the lens. This is performed by adjusting the focus and zoom rings of the camera lens, as described below:

### Procedure

1. With the **Focus Ring** set to the Far-focus (F,  $\infty$ ) position, aim the camera at a subject over 30 metres away.
2. Set the lens assembly to wide angle, and adjust the back focus by loosening the **Lock Ring** and then turning the lens assembly. Continue to turn the lens assembly until you achieve optimum image clarity
3. Check that you obtain sharp pictures at various zoom grades and various distances.

**Note:** If possible, it is better to perform this adjustment in low light conditions, or with a filter covering the front optic. This will ensure the iris is fully open to give the smallest depth of field, and therefore the best results.

---

## Appendix A - Troubleshooting

This appendix provides useful information to help you to resolve any difficulty you might have with your AXIS 2120. Fault symptoms, possible causes and remedial actions are provided in a quick reference table.

### Frequently Asked Questions

Q: Which modem should I select in the list on the Modem Settings page if mine is not listed?

A: *Generic.*

Q: Do I have to use one of the listed ISPs on the ISP Settings page?

A: *No. You can make whatever settings you like for your own ISP. You can use the name "Generic" for your own settings.*

Q: When should I use the Null Modem Cable?

A: *This cable is only intended as an alternative for configuring your camera when there is no network available.*

Q: Can I set up my camera to run as a PC-cam on my computer?

A: *No. The AXIS 2120 is a network camera for use only on Ethernet networks or with a modem.*

Q: Do I have to use the Wizards whenever I want to make changes?

A: *No. Everything which is configured in the Wizards can also be configured individually from the links on the left hand side of the Administration Tools page.*

Q: What are the ftp-path, the ftp-host name and ftp-user name?

A: *If you are uploading your images to an ftp-server, the ftp-path is the location of the directory on the remote ftp-server where you will be saving your images, the ftp-host is the name or IP-address of the ftp-server and the ftp-user name is the identity you use for logging in to the ftp-server.*

## PINGing Your IP Address

By sending a packet to the specified address and waiting for a reply, the *PING* utility can determine whether a specific IP address is accessible. It also provides a particularly useful method for confirming addressing conflicts with your AXIS 2120 on the network.

Having disconnected your AXIS 2120, follow the instructions below in association with *Symptoms, Possible Causes and Remedial Actions*, on page 52, and run the PING utility to troubleshoot TCP/IP problems on your network:

1. Start a DOS window.
2. Type `ping x.x.x.x`, where *x.x.x.x* is the IP address of the AXIS 2120.
3. The subsequent replies will provide an explanation as to the cause of the problem. Replies can be interpreted as defined in the table below:

PING Reply	Interpretation and recommendation
bytes = 32 time = 2 ms.....	The IP address is already used and cannot be used again. You must obtain a new IP address for your AXIS 2120.
destination host unreachable	The AXIS 2120 is not accessible within your subnet. You must obtain a new IP address.
request timed out	This IP address is not used by anyone and is available for use with your AXIS 2120.

## Symptoms, Possible Causes and Remedial Actions

Symptoms	Possible causes	Remedial actions
The AXIS 2120 cannot be accessed from a browser.	The IP address is already used by another device.	<ol style="list-style-type: none"> <li>1. Disconnect your AXIS 2120 from the network.</li> <li>2. Run the PING utility (as described in <i>PINGing Your IP Address</i>, on page 51) and follow the appropriate recommendations.</li> </ol> <p><b>Note:</b> The assigned IP number can be assumed valid if the PING utility returns "request timed out" - in which case you should set the IP address again, power on the AXIS 2120 and then try accessing the unit again.</p>
	The IP address is located on a different subnet.	<p>Run the PING utility (as described in <i>PINGing Your IP Address</i>, on page 51). If the utility returns "no response" or similar, the diagnosis is probably correct - you should then proceed as follows:</p> <p>In Windows 95/98 or Windows NT/2000, check that the IP address for your AXIS 2120 is on the same subnet as your workstation:</p> <ol style="list-style-type: none"> <li>1. Click "Start", "Settings", "Control Panel" and "Network".</li> <li>2. Specify the TCP/IP adapter and click on "Properties". In Properties, click "IP Address".</li> <li>3. If your AXIS 2120 is on a different subnet than your workstation, you will not be able to set the IP address from this workstation. Please contact your network administrator.</li> </ol>
	In Windows 95, the ARP table was empty when you tried to set the IP address.	<p>In Windows 95, the ARP command cannot be used if you have an empty ARP table.</p> <p>If the table is empty, re-install the product ensuring that the IP address for your own PC is also used. Type arp -a to view the ARP table.</p> <p>Note: The AXIS IP Installer provides a good alternative to ARP.</p>
	Possible problem with your proxy server.	Try disabling the proxy default in your browser.
	Other networking problems.	<p>Try replacing your network cable.</p> <p>Test the network interface of the product by connecting a local computer to the unit, using a standard <i>Crossover (hub-to-hub) Cable</i>.</p> <p>If the above actions do not resolve the problem, the AXIS 2120 may be faulty. In this case, try to localize the problem by connecting the AXIS 2120 to the serial port of a local computer, using the supplied <i>Null Modem Cable</i>; and report your findings to your local distributor.</p>

Symptoms	Possible causes	Remedial actions
The Power indicator is not constantly lit	Faulty power supply.	Verify that you are using an AXIS PS-D power supply.
The Network indicator displays red.	Faulty cabling.	<ol style="list-style-type: none"> <li>To verify that the cables are functional, PING the address of a known unit on your network.</li> <li>If the cabling is OK and your network is reachable, you should receive the reply similar to this:  <pre>...bytes = 32 time = 2 ms,</pre> </li> </ol>
The Active and Network indicators are flashing every 0.5 seconds	Hardware failure.	Contact your Axis dealer.
Your AXIS 2120 works locally, but not externally.	Firewall protection	Check the Internet firewall with your system manager.
	Default routers required	Check if you need to configure the default router settings.
Slow image updating	The Internet site is too heavily loaded	Configure the AXIS 2120 to upload your video images to an FTP server or an ISP.
No image using Refresh and/or slow updating of images.	Requests for images of varying size and resolution place a greater demand on the available file space within the AXIS 2120.	Ensure that all the clients accessing the images are using the same image resolution and compression. For large numbers of clients, configure the AXIS 2120 to upload your images to an FTP server or an ISP.
Cannot access the connected modem.	Modem not properly connected.	Check the modem power supply and modem cable connections, and ensure that the modem is configured appropriately.
	Incorrect initstring.	Send command AT&F1 to return your modem to factory default, and then try accessing the modem again. If this does not resolve the problem, it is likely that your modem uses an initialization string that is different from the standard ATZ command used by the AXIS 2120. In this case, refer to the user information supplied with your modem to find the unique initstring command for your unit.
A series of broad vertical white lines appear across the image.	The CCD sensor becomes overloaded when the light is too bright. This can happen e.g. with sunlight reflexes.	<p>Direct exposure to extreme sunlight or halogen light may cause serious damage to the CCD sensor. Reposition your AXIS 2120 in a more shaded location immediately.</p> <p><b>Note:</b> damage caused to the AXIS 2120 through over exposure to direct sunlight or halogen light is not covered by the product warranty.</p>

Symptoms	Possible causes	Remedial actions
Bad focus	Focus has not been correctly adjusted.	Referring to the on-line help, adjust the White Balance setting and then try resetting the camera focus again using the <i>Focus Assistant</i> , as described in <i>Adjusting the Camera Focus</i> on page 44.
	No adapter fitted with your C-type lens.	If you have previously replaced the supplied CS-type lens, you may have inadvertently installed a C-type lens - without the required adapter. See also page 47.
Noisy images.	Video images may be noisy if you are using the AXIS 2120 in a very low light environment.	To solve this problem, you need more light. The performance of the camera is best in 100 - 3000 lux. You may wish to consider replacing the basic lens with a more sensitive lens (Lower F-number), if the lighting in the installation area cannot be improved.
Bad quality images.	The Display Properties are incorrectly configured for your desktop.	Open the Display Properties in your desktop and configure your display to show at least 65000 colors, i.e. at least 16-bit.  <b>Note:</b> Using only 16 or 256 colors on your computer will produce dithering artifacts in the image.
	The camera is not focused correctly.	Referring to the on-line help, adjust the White Balance setting and then try resetting the camera focus again using the <i>Focus Assistant</i> , as described in <i>Adjusting the Camera Focus</i> on page 44.
No images available in your browser application.	ActiveX disabled.	If you are using Microsoft Internet Explorer, ensure that ActiveX has not been disabled in the Internet Options menu. Alternatively, use the Java Applet for viewing images.

**Note:** If you still have a problem after reading this information, please contact your reseller or check the FAQ on the AXIS 2120 product pages at the Axis Website at [www.axis.com](http://www.axis.com).

---

---

## Appendix B - Updating the Software

The AXIS 2120 camera software is stored in Flash memory. This memory is provided by a silicon chip that, just like any other ROM device, retains data content even after power is removed. Flash memory is unique because it allows its data to be erased and re-written. This means that you can install software updates for your AXIS 2120 as soon as they become available - without having to replace any parts. New software can be simply loaded into the AXIS 2120 over the network.

### Obtaining Updated Software

The latest version of the AXIS 2120 camera software is available free of charge from the Axis website at [www.axis.com](http://www.axis.com) or from your local distributor.

### Upgrading the Software

The AXIS 2120 Flash memory is upgraded over the network using FTP. See the detailed instructions supplied with each new software release.

#### Important!

- Always read the upgrade instructions available with each new release, prior to upgrading your software.
- Downloading normally takes between 30 seconds and 10 minutes, although it can take longer. After starting the download, you should always wait at least 20 minutes before power cycling the AXIS 2120 - even if you suspect the download procedure has failed.
- In controlled environments, flash memory upgrades provide a very safe method for updating software. However, flash products can become damaged if the upgrade operation is not performed correctly. Your dealer reserves the right to charge for any repair attributable to faulty upgrading by the user.

## Appendix C - The Unit Connectors

This section provides a detailed overview of the two supported product connectors; namely the **Serial Connector** and **IO Connector**. It also includes a schematic diagram describing how the AXIS 2120 is connected for a typical application:

### The Auto Iris Connector

The AXIS 2120 is supplied with a varifocal DC Iris lens that automatically regulates the amount of light entering the camera, and provides a distortion free wide-angle zoom.

The power and control signalling required for automatically adjusting the lens is supplied by the Auto Iris Connector that attaches to the lens via a connecting cable. The connector is located at the base of the camera, as illustrated below:

**DC-Iris cable.** Connected to the lens upon delivery, this cable supplies the power and electronic signalling to the lens from DC Iris connector.

Below: DC Iris connector  
- with cable removed.

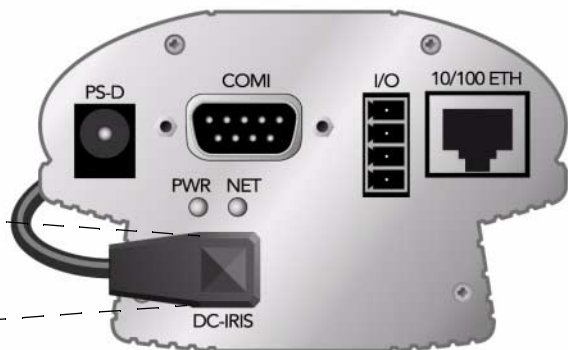

The AXIS 2120 is delivered with the Auto Iris cable already attached to the connector, and with the Auto Iris functionality enabled by default. Should you experience any problem with overexposure or white balance adjustment in your camera, check that the cable is firmly attached to the Auto Iris connector. Otherwise, the Auto Iris function requires no further intervention from the user. If you are unable to immediately resolve any apparent fault, refer to *Appendix A - Troubleshooting*.

### The Serial Connector

In the absence of a local network connection, the RS-232 serial connector provides a physical interface for connecting a modem or computer to the AXIS 2120. When a local network connection is unavailable at the point of installation, connect your PC to this connector using the supplied *Null Modem Cable* to initially configure your product.



### The Physical Connector

A single 9-pin D-sub connector provides the physical connection for the RS232 serial interface of the AXIS 2120. This connector is dedicated for use with an external modem and is suitable for speeds up to 115kbps.

A diagram of the RS-232 connector complete with pinout information is shown below.

Pin	Function
1	CD (Carrier Detect)
2	RXD (Receive Data)
3	TXD (Transmit Data)
4	DTR (Data Terminal Ready)
5	GND (Ground)
6	DSR (Data Signal Ready)
7	RTS (Return To Send)
8	CTS (Clear To Send)
9	RI (Ring Indicator)

A view of the RS-232 connector as seen from the rear of the AXIS 2120

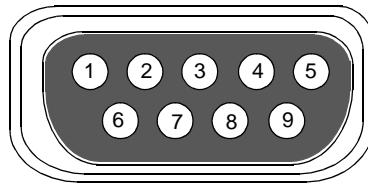

### The IO Connector

A 4-pole connector is provided for auxiliary IO connections to the AXIS 2120.

#### Physical Connector

The IO connector provides the interface to a single digital output and a single digital input. A diagram for the connector, complete with a pinout table, is provided below:

Pin	Function
1	Common Ground
2	Positive Connection for DC Power Input or Output: Electrically in parallel with the derived DC power for the unit, this pin may be used as a power input or output. As a power input it can be used for remote applications to supply the AXIS 2120 via an external direct current source; for example, a 9-15V DC battery supply. Used as a power output, it can drive the photo coupled input or other equipment; such as an infrared sensor. The output voltage level is dependent upon the input voltage to the unit. A maximum current of 50mA can be sourced from the DC output.
3	Digital Input (photo-coupled anode): Voltages 5-24V DC will activate the input. It is possible to use pin 2 to source the input.
4	Digital Transistor Output: With a maximum load of 100mA and maximum voltage of 24V DC, this output has an open-collector NPN transistor with the emitter connected to pin 1. If it is to be used with an external relay, a diode must be connected in parallel with the load for protection against any voltage transients - as detailed in the <i>Schematic Diagram</i> , on page 59. <b>Important!</b> Connecting AC to the transistor output will damage the unit.

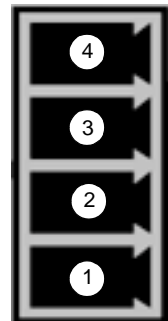

### Digital Input

Used for connecting external alarm devices and triggering images for specific alarm-based events, the digital input is typically connected to a motion detector (or any other external security device) for taking images on each occasion that the detector is activated.

### Digital Output

The supported transistor output can drive a maximum load of 24V DC at 100mA directly, and by connecting additional relay circuitry, can drive even heavier loads. From the **Administration Tools** you use **ON/OFF** buttons in the **Layout** settings to drive the output high or low.

**Schematic Diagram**

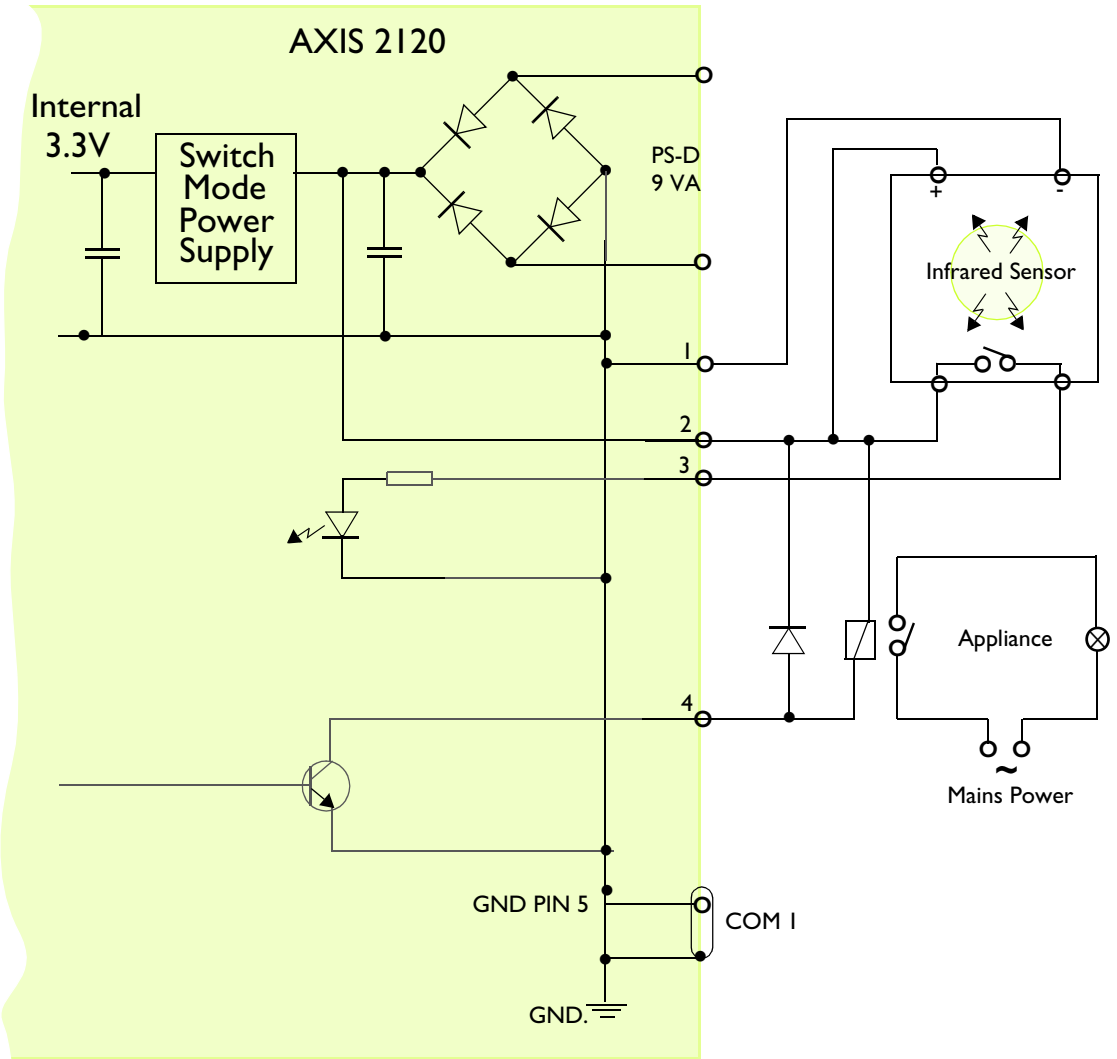

Schematic diagram of the I/O and RS232 connector - showing a possible application

**Caution!**

Pins 1 and 2 are connected to the derived DC power for the unit, and can be used as an external power feed for external equipment, such as an infrared sensor. When connecting other equipment using this connector, the maximum current of 50mA must be strictly observed. Failure to do so may cause a loss of power to the unit and may even damage your camera.

---

---

## Appendix D - High Speed Services

You will experience the full performance of the AXIS 2120 if you have access to high speed Internet services such as, xDSL or a cable modem connection. However, as most high speed Internet services only provide you with one external IP address, there are several practical issues that should be considered when developing your application.

### Available IP Addresses

Ideally, your ISP (Internet Service Provider) will provide you with several external static IP addresses - in which case you can assign any one of these to your AXIS 2120 to make it fully accessible over the internet. However, if your service provider supplies you with only one IP number - which is often the case - this IP number is normally assigned to your PC - leaving no connection available for your AXIS 2120. If your ISP is unable to provide you with an additional IP number, there are a number of other options that you may like to consider; including:

### NAT Box

Short for Network Address Translation, NAT is an Internet standard that allows a local-area network (LAN) to use one set of IP addresses for internal traffic and a second set of addresses for external traffic. A NAT box located where your LAN meets the Internet will handle all of the necessary IP address translations and provides:

- Internal IP addresses that are unique to your network - with no possibility of conflict with IP addresses used by other companies and organizations.
- The possibility of combining multiple ISDN connections into a single Internet connection.
- An effective firewall for hiding internal IP addresses

### NAT Feature in Windows 2000

Utilize the NAT feature in Windows 2000 to allow multiple Ethernet cards in your PC, and you can then use one port for the Internet and the other for your internal network. With this solution, you can let your AXIS 2120 upload image streams to an external Web server that is maintained and located with your ISP.

**Note:** For further details on Network Address Translation, see also RFC 1631.

### Routers and Firewalls

Another ideal solution is to use one of several small routers/firewalls currently available on the market. These provide the necessary NAT functionality and allow complete independence for your PC, which can be switched off or rebooted without effecting the image transmission from your AXIS 2120.

**WinGate Server Software:**

Running on a single Windows 95/98/2000 or NT computer, this software allows multiple users simultaneous access to the Internet through a single modem; ISDN; or high speed line, such as xDSL or cable modem connection; and effectively shares a single Internet connection with almost any type of client computer running TCP/IP.

For more advanced users, the WinGate 3.0 Standard and Pro versions also allow the administrator to change the IP bindings so that external requests may be routed specifically to your AXIS 2120 - running behind the WinGate software.

## Appendix E - Custom Web Pages

The AXIS 2120 contains a re-writable flash memory file system that allows some directories and files to be changed by the *root* user, using FTP (File Transfer Protocol). This strictly non-supported product functionality, makes it possible for advanced users and application developers to add their own Web pages, scripts, and other files to the Axis product.

### Caution!

Essentially a hidden feature within the AXIS 2120, modification of the flash file system is not supported by Axis Communications. In practice this means that Axis will not answer questions regarding Web page or script development.

In attempting to make any modification to the product, you may inadvertently create a problem that will require you to return the AXIS 2120 to its factory default settings. You may even cause permanent damage to the unit that renders it unusable. Consequently, Axis strongly recommends that inexperienced users DO NOT undertake any modifications described in this section.

Axis does not provide any support in association with this functionality nor take any responsibility for problems arising from it, but merely wish to inform potential application developers of the possibilities afforded by the Linux-based file structure of the AXIS 2120.

## Customizing Procedures

**Notes:** The existing Administration pages are stored in a compressed read-only area of the file system. If you intend to try changing these, you must strictly adhere to the instructions provided here and ensure that you DO NOT inadvertently change any files other than those featured in this section. Failure to comply with this notice may render your product unusable.

All files stored in the `/etc/httpd/html` directory are available through the product Web server in the virtual directory `/local/`. The URL to resident pages in the `/etc/httpd/html` directory is `http://IP/local/<filename>.htm`

## Editing and Storing Your Webpages

**Note:** Several demonstration and tutorial pages describe in some detail how to perform, execute, and implement various HTML development functions for your product.

Follow the instructions below to create and save customized pages to the AXIS 2120:

1. Using your preferred editor, create your html file and store it on your local PC hard drive.
2. Now use ftp to upload the file to the AXIS 2120. Enter the following on the command line:

```
ftp <camera ip address >
```

### Example:

```
ftp 172.21.1.200
```

3. Log on as *root* with the root password **pass**.
4. Change to the correct directory within the AXIS 2120 by entering the following command:

```
cd /etc/httpd/html
```

5. For binary storage of the files (not absolutely necessary, although good practice), type **bin**
6. Upload your html files by entering:

```
put <filename.html>
```

7. Start your browser and view the Web pages you have now uploaded, by entering the following URL in the location/Address field:

```
http://<camera ip address>/local/<filename.html>
```

**Example:**

```
http://172.21.1.200/local/index.html
```

The images are now updated in your browser.

**Note:** You can change the html files as and when you like, but remember that the available flash memory is limited.

8. Enter **bye** in the command window to exit the ftp program.

## Creating a New Home Page

Having created and stored your new custom Web pages in product memory, you then proceed to assign one of these pages as your default Home page in the AXIS 2120, as described below:

### Caution!

Adding a new Web page to your AXIS 2120 is not something that should be undertaken lightly. Remember: Axis does not support the personalization of product Web pages and strongly recommends that inexperienced users DO NOT perform such modifications.

1. Start a new ftp session to the AXIS 2120, by entering:

```
ftp <camera ip address >
```

2. type **bin**
3. Navigate your way to the appropriate directory, entering:

```
cd /etc/httpd/conf/
```

4. Fetch the *boa.conf* file, by typing:

```
get boa.conf
```

5. Add an alias to your own "homemade" index.html file stored in the */etc/httpd/html/* directory. This redirects access to your personalized Home page. For example:

```
Alias /usr/html/index.html /etc/httpd/html/index.html
```

**Note:** As an alternative to the above, you might like to edit the DocumentRoot so that it points directly to the local directory. However, after doing this you will then be unable to access the original Home pages - so be warned!

6. After making these changes, you must now type in the complete URL to access the normal index page:

```
http://IP#/view/index.shtml
```



---

---

## Appendix F - Technical Specifications

**System Requirements** - The AXIS 2120 uses the standard Internet TCP/IP suite of protocols and can be used with most operating systems: Windows 95, 98, NT and 2000, Linux, UNIX, Mac and others. The only software required is Microsoft Internet Explorer 4.x, or higher (used with Axis' ActiveX component AXIS Camera Control), or Netscape 4.x.

**Installation** - Physical network connection using RJ-45 twisted pair cable. Remote connection using any standard serial modem, or local computer connected using the a Null Modem cable.

**Management** - Remote configuration and status using Web-based Administration Tools.

**Image Features** - Time/date stamp, text overlay, variable size, rotation, color CGI control, and in-picture motion detection.

**Image Resolution** - CIF = 352 × 288, QCIF = 176 × 144, 4CIF = 704 × 576

**Networking** - 10baseT Ethernet or 100baseTX Fast Ethernet, TCP/IP, HTTP, FTP, SMTP, NTP, ARP and BOOTP.

**I/O Connector** - Providing a single optical-isolated alarm input, and a single digital output (max 24V, 0.1A) that features a programmable digital input/output for remote image storage via File Transfer Protocol (FTP) or E-mail (SMTP), pre/post alarm image storage.

**Pre/Post Alarm Buffer** - Up to 8 MByte memory available for pre/post alarm image storage.

**Modem Connector** - Single 9-pin D-SUB RS232 connector, max 115 kbps, half-duplex.

**Security** - Multi-user password protection.

**Operating Conditions:** - Temp: 41 to 122° F (+5 to +50° C), Humidity: 8 - 80% RHG.

**Approvals** - EMC: FCC Class A, **CE** :EN55024/1998, Emission: C-Tick (Australia), VCCI (Japan), Safety: EN 60950, UL, CSA.

**Metrics:** - Height: 2.2" (5.7 cm), Width: 3.4" (8.6 cm), Length: 5.4" + lens 1.8" = 7.2" (13.8 cm + 4.5 cm = 18.3 cm), Weight: 0.55 lb. (0.25 kg) - excluding power supply.

**Hardware** - ARTPEC-1 compression chip; ETRAX-100, including, 32 bit RISC, 100 MIPS CPU, 16 Mbyte DRAM, 4 Mbytes FLASH PROM.

**Camera Lens** - Varifocal DC Iris lens with CS Mount, manual zoom, variable focus, and exposure control. Variable shutter speeds between 1/50 - 1/10000 (PAL) and 1/60 - 1/10000 (NTSC).

**Power** - External power supply 12V AC, 9.6 VA (PS-D, included), 9-15V AC, min 10VA, or 9-15V DC, min 8W.

**Complimentary Software** - AXIS IP Installer for quick installation of multiple units. AXIS Camera Control (Axis' ActiveX component software required for Microsoft Internet Explorer). Java Applet as alternative to ActiveX.

**Compression and Performance** - The AXIS 2120 delivers Motion-JPEG images at up to 25 images per second, as well as single JPEG images that feature user controlled compression levels. See also *Picture frequency for Networking Applications*, on page 35.

All specifications are subject to change without prior notice.

# Index

## A

- Access rights 30
  - Admin 30
  - Dial-in 30
  - View 30
- Administration Tools 27
- Anonymous user access 30
- AppleTalk 18
- ARP 52
- ARTPEC-1 6, 65
- AXIS IP Installer 15

## B

- Boa Web server 7
- BOOTP 15, 17

## C

- CGI scripts 6
- Compression 6, 35
- Configuring 25
- Connectors 56

## D

- Dial-up Networking 22
- Digital input 58
- Digital output 58

## E

- E-mail 6
- Ethernet 5
- Ethernet address 15
- ETRAX-100 6, 65

## F

- Factory Default Settings 33
- Fast Ethernet 5
- Firewalls 60
- Focus Assistant 45
- Focus Quality 45
- Focus Ring 44

## H

- Home page 14
- HTTP 6

## I

- I/O Connector 9
- Installation 12
- Internet address 52

## L

- Linux 7, 65
- Lock Ring 44

## M

- Macintosh users 18
- Motion Detection 31
- Motion Indicator 32
- Motion Window
  - Profile sliders 32
- Motion window 32
- Mounting assembly 11

## N

- Network Address Translation 60
- Network Connector 9
- Network Indicator 9
- Network indicator 53
- Network installation 12
- Null Modem Cable 21

## O

- Obtaining updated software 55

## P

- performance 66
- Power indicator 53
- Power supply connector 9
- PPP 7
- problems 50, 56

## R

- Routers 60
- RS232 connector 9
  - diagram 57

## S

- Serial number 8
- SMTP 6
- Status Indicator 45
- System Requirements 65

## T

- technical specifications 65
- triggering images 58
- troubleshooting 50, 56

## W

- Wide/Tele Zoom 44
- WinGate 61

## X

- xDSL 60

## Glossary of Terms

**ActiveX** - A control (or set of rules) used by a browser. ActiveX controls are often downloaded and installed automatically as required.

**ARP** - Address Resolution Protocol. A protocol for assigning an IP address to a physical device address that is recognized in the local network. The ARP command can be used to set the IP-address for your product.

**ARTPEC** - Axis Real Time Picture Encoder - used for image compression.

**BOOTP** - A protocol that can automatically configure a network device (give it an IP address).

**Bps** - Bits per second. A unit for measuring speeds in networks. A LAN might run at 10Mbps or 100Mbps.

**CGI** - Common Gateway Interface. A set of rules (or a program) that allows a Web Server to communicate with other programs.

**DSL** - Digital Subscriber Line. A means of transferring data via standard phone lines.

**Ethernet** - A widely used networking standard.

**ETRAX** - Axis' own microprocessor.

**Firewall** - A virtual barrier between a LAN (Local Area Network) and other networks, e.g. the Internet.

**Frame Grabber card** - Plug-in hardware for "grabbing" images

**FTP** - File Transfer Protocol. Used for simple transfer of files to and from an ftp-server.

**HTML** - Hypertext Mark-up Language. Used widely for authoring documents viewed in web browsers.

**HTTP** - Hypertext Transfer Protocol. The set of rules for exchanging files (text, images, sound, video, and other files) on the World Wide Web.

**Intranet** - A private network limited to an organisation or corporation. Usually closed to external traffic.

**IP** - Internet-Protocol. See TCP/IP.

**IP number (address)** - A unique number used by a computer on the network to allow it to be identified and found.

**JPEG** - A standard image format, used widely for photographs. Also known as JPG.

**LAN** - A local area network (LAN) is a group of computers and associated devices that typically share common resources within a limited geographical area.

**Linux** - A popular operating system, that is "open source" and practically free of charge.

**Lux** - A standard unit for light measurement.

**NWAY** - A network protocol that automatically negotiates the highest possible common transmission speed between two devices.

**Null Modem Cable** - A cable used for connecting a PC to a serial device, using the modem protocol for communication.

**PING** - A small utility used for sending data packets to network resources to check that they are working and that the network is intact.

**PPP** - Point-to-Point Protocol. A method allowing one computer to connect to another, usually via a modem over a phone line.

**Pre/post alarm image** - The images from immediately before and after an alarm.

**Protocol** - A special set of rules governing how two entities will communicate. Protocols are found at many levels of communication, and there are hardware protocols and software protocols.

**SMTP** - A common e-mail protocol.

**TCP/IP** - Transmission Control Protocol/Internet Protocol. A suite of network protocols that determine how data is transmitted. TCP/IP is used on many networks, including the Internet. TCP keeps track of the individual packets of information and IP contains the rules for how the packets are actually sent and received.

**URL** - Uniform Resource Locator. An "address" on the network.

**V.90** - An operating standard for telephone modems.

**WAN** - Wide-Area-Network. Similar to a LAN, but on a larger geographical scale.

**Web server** - A program on a computer that delivers the resources (usually web pages) requested by the web user (the client).

**Wizard** - A program designed specifically to guide the user through a procedure. Typically used for installations and configurations.