



User's Manual

AXIS 2460 Network DVR

Local Recording, Global Access



AXIS[®]
COMMUNICATIONS

About This Document

This document is intended for both administrators and users of the AXIS 2460 Network DVR, and is applicable for firmware release 3.0 and above. The document contains information for configuring, managing and using the unit, as well as a general overview of the product functionality. Detailed instructions for using the product are also available in the on-line Help.

Readers are recommended to use this document as a supplement to the on-line information available via the Web-based interface. Later versions of this document will be posted to the Axis Website, as and when required.

Safety

Caution - To prevent fire or electrical shock, do not expose the unit to rain or moisture, nor remove the cover. For service, please return the unit to the place of purchase.

The AXIS 2460 conforms to the safety standard EN60950, C-UL.

Please observe the following notices when using this product:
Caution! - Potential hazard that can damage the product.

Important! - Potential hazard that can seriously impair operation.

Do not proceed beyond any of the above notices until you have fully understood the implications.

Legal Considerations

Camera surveillance may be prohibited by laws that vary from country to country. Check the laws in your local region before using the AXIS 2460 for surveillance purposes.

Electromagnetic Compatibility (EMC)

USA - This equipment generates, uses, and can radiate radio frequency energy, and if not installed and used in accordance with the instruction manual, may cause interference to radio communications. It has been tested and found to comply with the limits for a Class A computing device pursuant to Subpart B of Part 15 of FCC rules, which are designed to provide reasonable protection against such interference when operated in a commercial environment. Operation of this equipment in a residential area is likely to cause interference in which case the user at his/her own expense will be required to take whatever measures may be required to correct the interference. Shielded cables should be used with this unit to ensure compliance with the Class A limits.

Europe **CE** - This digital equipment fulfills the requirements for radiated emission according to limit B of EN55022/1994, and the requirements for immunity according to EN55024/1998 residential, commercial, and light industry.

Liability

Every care has been taken in the preparation of this manual. If you detect any inaccuracies or omissions, please inform your local Axis office. Axis Communications AB cannot be held responsible for any technical or typographical errors and reserves the right to make changes to the product and manuals without prior notice. Axis Communications AB makes no warranty of any kind with regard to the material contained within this document, including, but not limited to, the implied warranties of merchantability and fitness for a particular purpose. Axis Communications AB shall not be liable nor responsible for incidental or consequential damages in connection with the furnishing, performance or use of this material.

Trademark Acknowledgments

Acrobat, Adobe, Boa, Ethernet, IBM, Internet Explorer, LAN Manager, Linux, Macintosh, Microsoft, Netscape Navigator, OS/2, UNIX, Windows, WWW are registered trademarks of the respective holders. Java and all Java-based trademarks and logos are trademarks or registered trademarks of Sun Microsystems, Inc. in the United States and other countries. Axis Communications AB is independent of Sun Microsystems Inc.

Support Services

Should you require any technical assistance, please contact your local dealer. If your questions cannot be answered immediately, your dealer will forward your queries through the appropriate channels to ensure a rapid response. If you are connected to the Internet, you can obtain on-line manuals, technical support, software updates, application software and general corporate information from www.axis.com

<p>AXIS 2460 Network DVR User's Manual Revision 1.0 Part No: 18933 Dated: March 2002 Copyright © Axis Communications AB, 2002</p>

Table of Contents

Product Overview	5
Features and Benefits	5
Description	9
The Front Panel	9
The Rear Panel	10
Checking The Hardware Inventory	11
Installing the AXIS 2460 Network DVR	12
Network Installation	12
Installing via the Null Modem Cable	15
Connecting and Configuring Cameras	18
Complete Camera Settings	19
Setting up Events and Alarms	20
About Events	20
The Recording Options Overview	20
Creating a Simple Event	21
Configuring Alarms	22
Creating an Alarm-Controlled Event	22
Complete Event Settings	23
Complete Alarm Settings	27
Event Examples	27
Working with Recordings	29
The AXIS Video Player	32
Creating an AVI Movie	34
About Codecs	35
System Options	36
System Options Overview	38
Network Settings	39
Mail Settings	40
COM-Ports	41
Modem Settings	41
ISP Settings	42
Date & Time	43
Users	44
Firewall Settings	45
Maintenance	46
Support	47

The Factory Default Settings	48
Appendix A - Recording Storage and Reduction	49
Appendix B - The LED Indicators	53
Appendix C - Troubleshooting	54
Appendix D - Other IP Setup Methods	57
Appendix E - Updating the Firmware	60
Appendix F - Installing Hard Disks	61
Appendix G - Unit Connectors	63
Appendix H - Technical Specifications	68
Index	70

Product Overview

The AXIS 2460 Network DVR (Digital Video Recorder) records directly from up to four analog video cameras via standard video cabling. All administration and viewing of recorded material is via a standard web browser (Internet Explorer) over a TCP/IP network.

The AXIS 2460 includes all of the necessary components for recording and viewing recorded sequences over the network, including its own built-in Web server, providing full Web-based control of the product management and configuration functions via a browser over the network.



The AXIS 2460 Network DVR

Used primarily via a direct Ethernet or Fast Ethernet network connection, the AXIS 2460 can also connect to an Internet Service Provider using an external modem.

The installation process is simple and the product integrates seamlessly into your networking and application environments. The AXIS 2460 offers a cost-effective imaging solution with minimal installation and maintenance costs.

Features and Benefits

Ease of Use - The AXIS 2460 Network DVR:

- is completely independent of any other server.
- is easily installed, simply by assigning an IP address.
- requires no further hardware such as PC frame-grabber cards.
- only needs Microsoft Internet Explorer 5.0 or higher for viewing live images or recordings over the network.
- runs with Windows 98, ME, XP, NT and 2000.

Recordings - The AXIS 2460 allows continuous unattended recording to a hard disk. Live images can be viewed while recording, administration can be performed at any time, and playback can be started while other recordings are in progress. Digital image storage eliminates the multiple-use degradation associated with video tapes.

- Remote access from any PC over the network.
- Continuous, event/alarm, manual and scheduled recording modes.
- Records and displays events directly – no waiting for tapes to engage or rewind.
- Event driven recording maximizes disk space by only recording when an event is detected.
- Instant video retrieval from recordings list.
- Automatic removal of recordings older than X days/hours can be enabled.
- Searchable Recordings List.
- No glitches when changing tapes, or forgetting to change tapes.

Optimized Storage/reduction - The AXIS 2460 manages the recordings stored on its disks via a system that makes the best use of the available space. A special reduction algorithm, the patent-pending Axis APViS, ensures that the recordings you designate as "important" are retained for much longer than when using a simple FIFO (First-in First-out) system. Instead of abruptly deleting recordings, the reduction algorithm gradually reduces the recording's frame rate, thus saving on disk space and allowing the recording to be kept for much longer. The reduction process is fully configurable and recordings can also be locked, thus preventing any reduction.

Secure Storage - The AXIS 2460 ensures that no recordings are totally lost in the case of a disk failure. This is accomplished by virtue of the fact that a recording consists of a series of images that are much the same and which are distributed among all the connected hard disks in a sequential fashion. If every fourth image is lost, this only means a reduction in frame rate, not that all the information is lost. In this way, important surveillance video is assured, even in the unlikely event of a hard disk failure.

As an example, if you have 4 hard disks and one of them fails, the reduction in frame rate will be (100/4) %.

Built-in Video Player - No need for extra viewing software. Simply click on the desired recording in the recordings list in your browser and the AXIS Video Player starts automatically.

- Playback and forward/reverse search at adjustable speeds, or view frame-by-frame.
- Playback by date/time, event and camera.
- Playback by choosing a recording from the recording list.
- Snapshots are easily saved, and AVI movies can be quickly created using the AXIS AVI Maker ActiveX component (included).

Live Viewing - Quad or single display of live images in your browser. No other software required.

Simple Administration - Using a standard browser (Internet Explorer), all of the AXIS 2460's functions are configured and managed over the network, directly from its own Web pages. There are global settings and there are individual event settings.

Security - Access can be restricted to defined users only, at three different authorization levels, from Administrator to Viewer. Passwords ensure protection against unauthorized or unintentional recording, playback or administration. The built-in firewall guards against unauthorized use of the AXIS 2460.

Fully Configurable Event Settings - The AXIS 2460 makes it easy to set up events. When all of the criteria for the event have been fulfilled, the event will begin to record. It is also possible to configure pre-buffers and a fixed recording duration, as well as send event notification via e-mail.

Alarm Inputs and External Devices - Up to four separate alarm devices can be used to trigger events (recordings). The single output relay can be used to control external equipment. Supporting the RS-232 and RS-485 communication protocols, the AXIS 2460 includes the physical interfaces for connecting a variety of external devices, such as; doorbells, switches and alarm relays. You can even drive annunciators and other audible alarm devices using the relay output.

Cost-effective - The AXIS 2460 provides a reliable and low-cost resource for high-quality recordings and imaging over the network. Requires none of the hidden accessories normally required by other imaging systems, such as expensive software, management workstations, dedicated applications or PC frame-grabber cards.

Open Standards Environment - The AXIS 2460 supports TCP/IP networking, SMTP, HTTP and other Internet-related protocols. It integrates easily into other WWW/Intranet applications and CGI scripts. Note however, that only Internet Explorer on Windows can display live images and recordings.

Image Updating - The on-board AXIS ETRAX 100-LX processor combined with the revolutionary AXIS ARTPEC-1 Real Time Picture Encoder provides an amazing power-synergy to deliver up to 25/30 frames/second over 10Mbps or 100Mbps networks.

High Compression - The AXIS ARTPEC chip affords both an efficient and variable ratio of JPEG image compression that can be defined by the user.

Modem Support - The Point-to-Point Protocol (PPP) support allows you to use your AXIS 2460 remotely over a serial link, just as if it were located on your local network. You can initially set up the unit over the network, or from a computer connected directly by the supplied Null Modem cable, and then access it via a standard *Dial-up* (PPP) connection.

Linux Operating System - The AXIS 2460 includes modified versions of the Boa Web server, and Linux operating system - both of which are freely distributed under the GNU General Public License, as published by the Free Software Foundation. This software provides a stable and reliable platform for open-source development of the product. In accordance with the *GNU General Public License*, Axis has published the kernel for this product at <http://developer.axis.com/>.

Description

Please read the following information to familiarize yourself with the AXIS 2460, making particular note of where the connectors and indicators are located. This section provides a useful reference when installing the product.

The Front Panel

Please refer to the numbered explanations for a brief description of the indicators on the front panel.

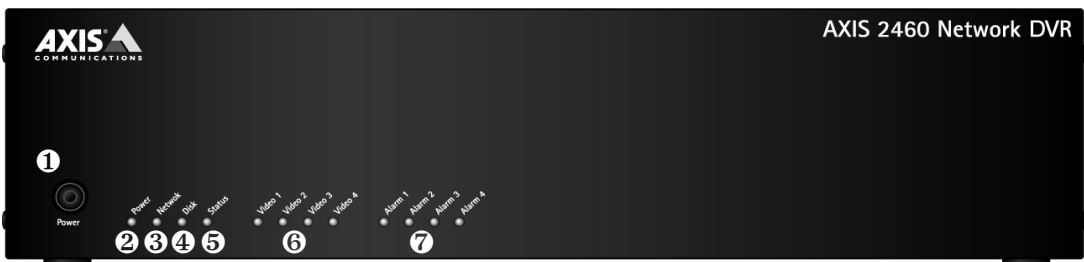

1 Power Button - To switch the unit ON, simply press the button once. To switch the unit OFF, press and hold the button in for 1-2 seconds, until the power indicator **2** turns Amber. The shutdown process will then continue and can take up to 60 seconds to complete. This saves settings, recordings etc, before shutting down. If the power is simply disconnected, there will be a serious risk of losing recorded material.

2 Power - The Power indicator shows Green during normal operation.

3 Network - The Network indicator flashes for network activity. A solid Red indicator signifies no network connection.

4 Disk - The Disk indicator flashes Amber when writing to the disk, and Green when reading.

5 Status - The Status indicator shows Green for normal operation.

6 Video 1-4 - The indicators for the video inputs indicate if the input is enabled and if recording is in progress.

7 Alarm 1-4 - The indicators show Yellow to indicate an alarm on the input.

Note: For a complete listing of the LED indicator colors and their meanings, please see *The LED Indicators*, on page 53.

The Rear Panel

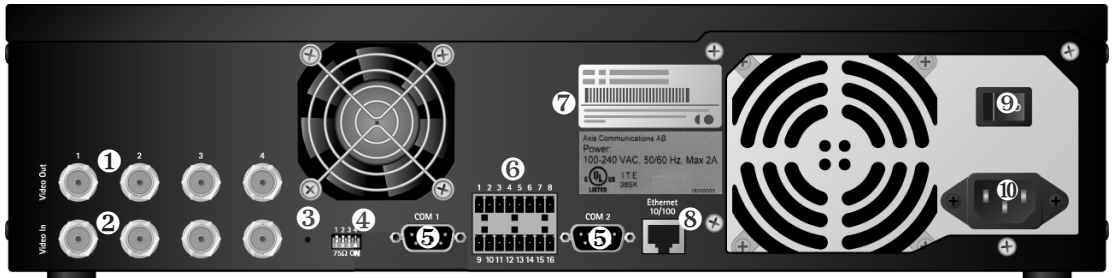

- ❶ **Video Outputs (4)** - These outputs provide loop-through connections, and can be used for direct monitoring of the connected video cameras.
- ❷ **Video Inputs (4)** - Connect your standard PAL or NTSC video cameras to these inputs.
- ❸ **Factory Default button** - This button will reset the unit to the original factory default settings. Use a paperclip or similar to press the button. See also *The Factory Default Settings*, on page 48.
- ❹ **Dip switches** - Each video output has a single line termination switch. All units are shipped with the line termination enabled for each input; that is, with the DIP switches set in the down position. When, for example, a monitor is connected in parallel with the video input (to monitor the input directly), the input termination should be disabled - by turning the corresponding DIP switch to the up-position (OFF). Failure to do this can cause the picture quality to be impaired.
- ❺ **COM-Ports** - These 9-pin D-SUB serial ports can be used for:
 - COM-1 - RS-232, max 230 Kbps. This port is multiplexed with the RS-485 port on the terminal block, that is, only one of the protocols can be used at a time.
 - COM-2 - RS-232, max 38.4 Kbps, half-duplex. A modem is connected here.
- ❻ **Terminal Block Connector** - 4 Alarm inputs, 1 relay output, and the RS-485 port are connected via the terminal block. See *Unit Connectors*, on page 63 for more information.
- ❼ **Serial Number** - This serial number is used for setting the IP address.
- ❽ **Network Connector** - 10baseT Ethernet or 100baseTX Fast Ethernet via the RJ-45 socket.
- ❾ **Main Power Switch** - This switch should only be used after shutting down the unit correctly with the help of the Power button on the front panel. Switch the unit off here if you need to e.g. move the unit to another location, or to install a hard disk.
- ❿ **Power Connector** - Connect the power cable here. Using an Uninterruptible Power Supply (UPS) is strongly recommended.

Mounting the Recorder

Important!

The AXIS 2460 is intended for indoor use only.

The unit is designed for conventional rack mounting, using the 2 brackets and screws supplied. To fit the brackets, remove the 2 foremost screws on each side panel and then screw the bracket on, as shown in the illustration below.

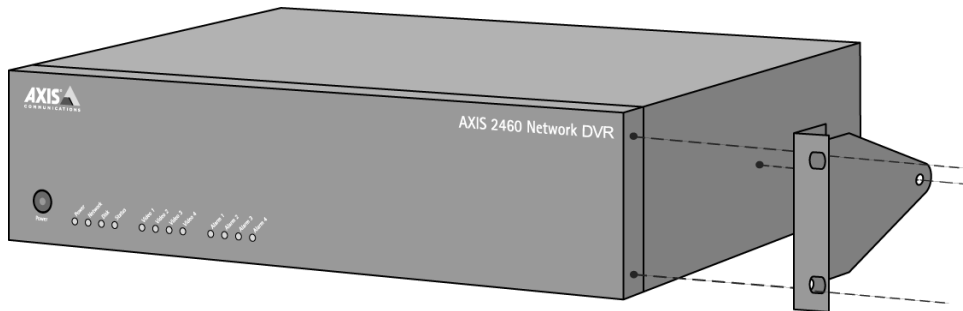

Remove the 2 screws on the side panel. Mount the bracket as shown, using one of the supplied screws for the third hole.

Checking The Hardware Inventory

Check the items supplied with your AXIS 2460 against the list below and contact your dealer if you find anything is missing or damaged.

Item	Description	Part Numbers	Item	Description	Part Numbers
AXIS 2460	Network DVR	0138-001-01 ¹	Power Cord ²		2
Null Modem Cable	1m	16954	Rack Holder Kit	2 brackets, 2 screws	18840
This Document	AXIS 2460 User's Manual v1.0	18933	2 x Hard disk Holder Kit ³		18839
Disk Media	AXIS Network Camera CD v2.1 (or later)		Warranty Document		18640

¹The part number for your AXIS 2460 Network DVR depends on the country of purchase and the number of hard disks installed.

²The part number for the power cord depends on the country of purchase.

³ If the unit is supplied with hard disks, then these kits are already installed.

Installing the AXIS 2460 Network DVR

Before you begin the installation of your AXIS 2460 Network DVR, please read the following notice concerning operating systems and browsers:

Important!

The AXIS 2460 was developed for use with Microsoft Internet Explorer (5.0 or higher) running on Windows 98/ME/XP/NT or 2000. This is because the viewing of live images and the built-in Video Player both require an ActiveX control for their function, which is currently only supported by Internet Explorer. Other browsers and other operating systems can be used for installing the unit and for administration purposes, but live images and the Video Player will not function correctly.

Network Installation

- Easy installation - Use The AXIS IP Installer. See *Using the AXIS IP Installer* on page 58.
- Quick installation - Follow the instructions below to install the AXIS 2460 onto an Ethernet network.
- Macintosh users - Please refer to *Notes for Macintosh Users* on page 59.

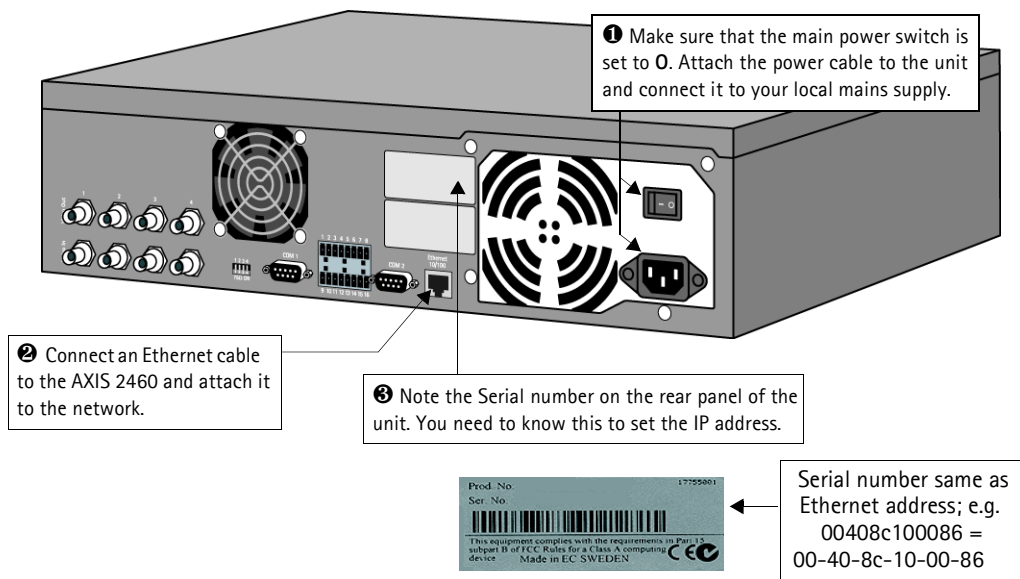

4 Setting the IP address using ARP and PING (as described below) will require Administrator privileges on Windows NT, Windows 2000 and Windows XP Professional. This is not required for Windows 98, ME or XP Home. Use of the arp command on UNIX systems may require root access.

Using the appropriate method for your operating system, assign your product with a unique IP address (do not use the example below) from a computer on your network, as follows:

Windows - Start a command prompt and type these commands:

Syntax:

```
arp -s <IP address> <Ethernet address> <my PC IP address>
ping -t <IP address>
```

Example:

```
arp -s 123.123.123.123 00-40-8c-10-00-86 123.123.123.122
ping -t 123.123.123.123
```

UNIX - Type these commands in your command line:

Syntax:

```
arp -s <IP address> <Ethernet address> temp
ping <IP address>
```

Example:

```
arp -s 123.123.123.123 00:40:8c:10:00:86 temp
ping 123.123.123.123
```

Note: On some UNIX systems, the arp command can be located in a directory that is not on the command path.

You will now see 'Request timed out...' messages repeatedly returned in the command window.

- 5 Now turn the main power switch on the rear panel to I.
- 6 After approximately 30-40 seconds, the message 'Reply from 123.123.123.123..' or similar, is returned within the prompt window. Check that the Power Indicator is permanently lit and that the Network Indicator flashes intermittently.
- 7 Exit Ping. The IP address has now been set and you are ready to access the AXIS 2460 from your browser, as described below.

Verifying and Completing the Installation From Your Browser

1. Start your browser and enter the IP address of your AXIS 2460 in the location/address field. Any cameras connected to the unit will be shown as *disabled*. Click the links provided to enable them. See also *Connecting and Configuring Cameras* on page 18.

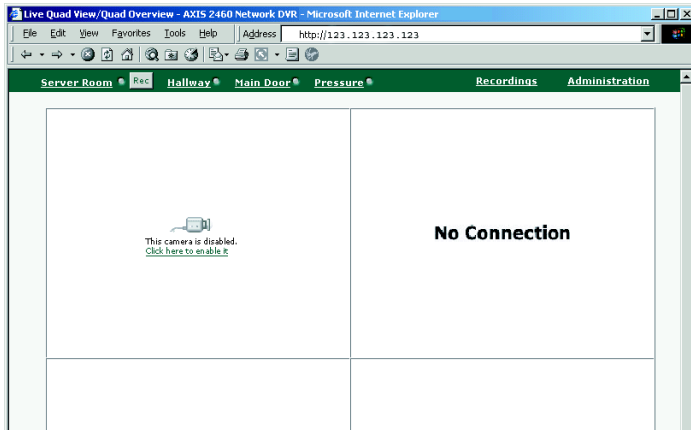

2. After connecting and enabling your cameras, live images will then be visible in your browser. To see the image from a single camera, click on the camera link above the images.

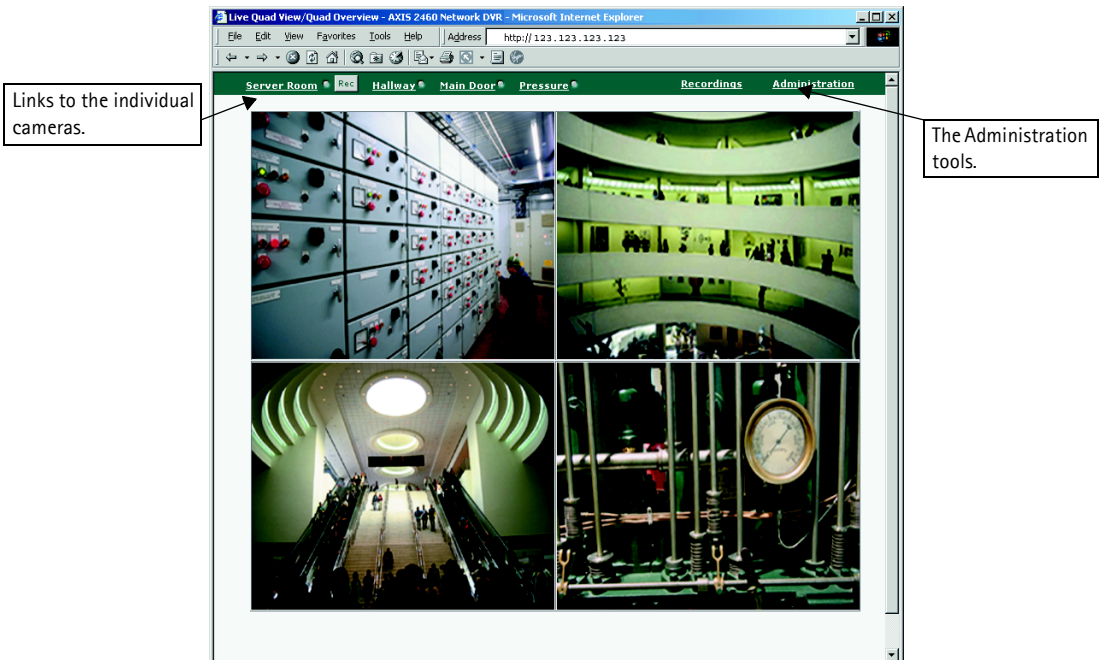

3. Continue the unit's configuration using the Administration Tools.

Installing via the Null Modem Cable

This section describes how to install the AXIS 2460 using the null modem cable. For information on how to configure the unit for modem operation, please see the configuration section.

Important!

- Although instructions for installing the AXIS 2460 using a null modem cable are provided below, it is recommended that, whenever possible, the unit is initially installed and configured over a network.
- The information and examples featured here are specific to Windows 2000, but the process is similar in other versions of Windows. Refer to your system information for further information on creating a Dial-Up Networking connection if you are using any other operating system.
- Windows Dial-Up Networking and TCP/IP must be correctly installed prior to commencing with the modem cable connection. Detailed information on how to check this is provided in Windows Help.

Connecting Your Computer Using the Null Modem Cable

1 Connect the supplied Null modem cable between the COM-2 Serial Connector on the AXIS 2460 and the COM-port on your computer. 2 Press the Power button on the front panel and check that the Power Indicator lights up.

3 From the Start menu, open the Control Panel and click *Phone and Modem Options*. Select *Modems*.

4 If a Standard Modem is already set up, you should proceed directly to the next page. If no modem is installed, click *Add* and go to step 5.

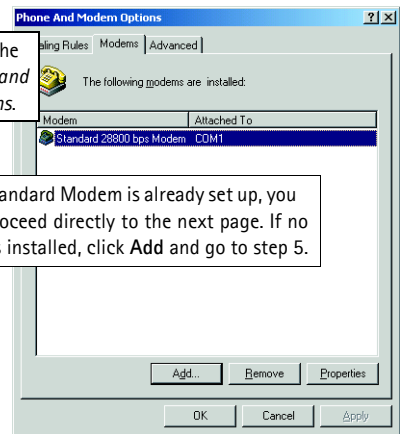
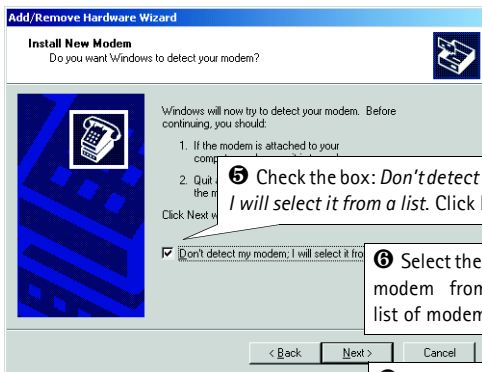

7 Select the serial port to which your AXIS 2460 is now connected via the Null Modem cable. Click *Next>*.

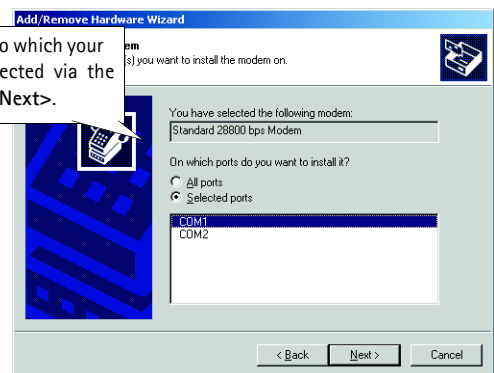
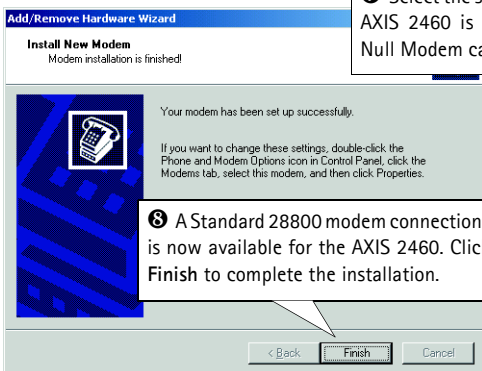

Creating a Dial-Up Networking Connection

Follow the steps below to create a dedicated Dial-Up networking connection to your Network DVR:

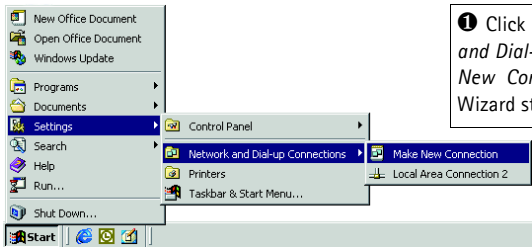

1 Click the *Start* button, *Settings*, *Network and Dial-up Connections*, and finally, *Make New Connection*. Click *Next>* when the Wizard starts.

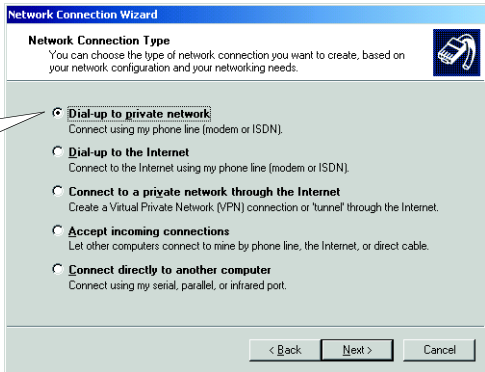

2 Set the type of connection as *Dial-up to Private Network*. Click *Next*.

3 A telephone number is requested in this dialog, but as it won't actually be used, simply enter any dummy number. Click *Next>*.

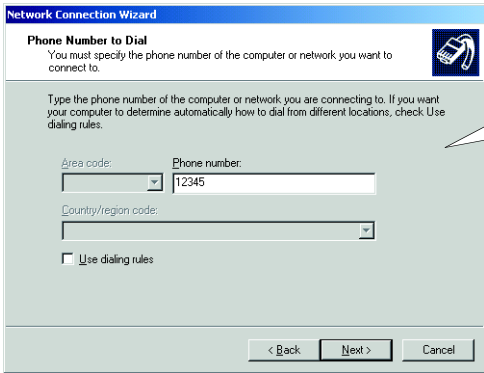

4 Provide the connection with a name (*Axis* in our example) and then click *Finish*.



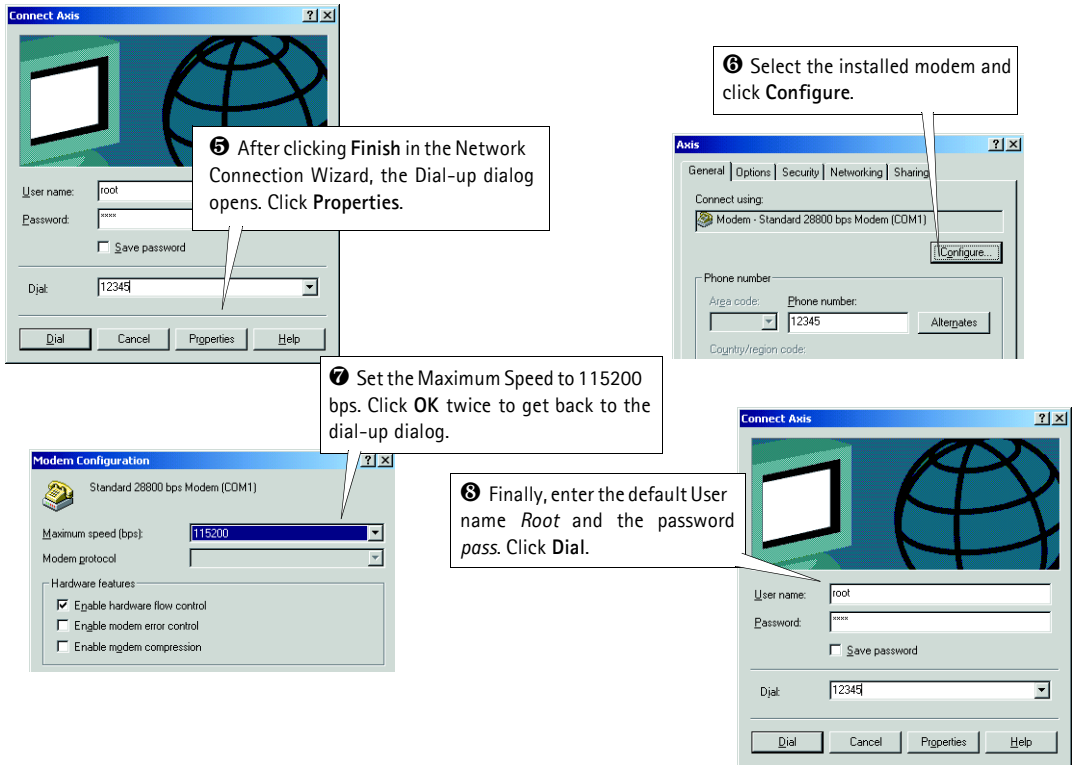

Step 3 – Verifying the Connection and Completing the Installation

Having started your Dial-Up connection, as described above, you can quickly test the connection by accessing the AXIS 2460 from your browser (Internet Explorer).

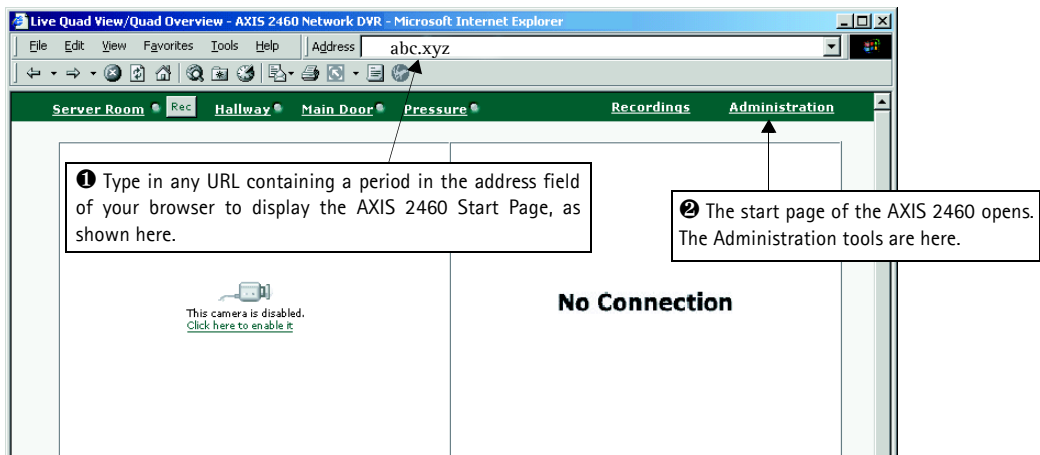

The cameras will be shown as *disabled* or there will be *No connection*. See *Connecting and Configuring Cameras* on page 18 for information on how to enable cameras.

Connecting and Configuring Cameras

Up to four standard analog video cameras can be connected to the AXIS 2460. The connectors are located on the rear panel (see also page 10) and the status for each input is indicated on the front panel by an LED (see page 9).

1. Position the camera as required.
2. Connect the camera to the input on the rear panel of the Network DVR.



3. Connect power to the camera.
4. Now start your browser and enter the IP address of your AXIS 2460, as described in the installation section. The camera will probably be indicated as being *Disabled*. Click the link provided to go to the configuration page for the camera, and enable it by checking the box. Click **Save** and then return to *Live Quad View*.

If for some reason the camera should stop functioning, e.g. a loss of power or a cable break, the LED for the input on the front panel will show red, and the image in the browser will go black.

Note: The camera will automatically start recording as soon as it is enabled. This is controlled by a default event called **Continuous Recording**, which is supplied pre-configured with the unit.

Complete Camera Settings

The **Camera Options** provide the tools for configuring the cameras connected to the AXIS 2460. These tools are accessed from the administration tools on the left hand side of the main window. Click the **Edit** button to set or change the configuration for the camera.

The following settings are available for each camera:

Enabled - Check this box to enable the camera. A disabled camera cannot be used to record from.

Camera Name - The name you provide here for the camera will be used in image headings and in all menus that show camera names.

Use ... in the Image Heading - Check the relevant box to include the camera name, date and/or time in image headings.

Color Settings - Choose to view the camera images in black & white or in color. *Black & white* generates smaller file sizes and the contrast is usually higher than when using color.

Image Resolution - Select *Low*, *Normal* or *High* resolution. High resolution will reduce the frame rate, due to the larger file sizes involved. The exact resolutions are as follows;

- QCIF = 176 x 112 (NTSC), 176 x 144 (PAL) - Low resolution
- CIF = 352 x 240 (NTSC), 352 x 288 (PAL) - Normal resolution
- 4CIF = 704 x 480 (NTSC), 704 x 576 (PAL) - High resolution

Image Compression - Select the level of compression for your images. Lower compression optimizes picture quality, but generates larger image file sizes.

Offset Adjustment - Enter values in these fields to change the horizontal and vertical synchronization for the image. This can be used to eliminate any black border surrounding the image.

Note: The settings for Color, Resolution and Compression will all affect the size of the generated files. This will also affect the length of time the recordings are stored for.

Input/Modulation for Camera

Automatically Detect and Store - Click the button to have the AXIS 2460 automatically detect the modulation type for the connected camera.

Set Manually - Select the correct video modulation type from the drop-down list.

After making these settings, click **Save**.

Setting up Events and Alarms

The AXIS 2460 Network DVR can be used in a wide variety of surveillance applications and can also use external alarm devices and output equipment. Using the Web interface, it is a simple matter to configure events, alarms and recordings.

This section describes how to configure events and alarms and provides a few examples of typical applications. For a complete rundown of all the available settings, please see *Complete Event Settings*, on page 23.

You may also need to make various other general settings, for example, define users, set the date and time, make network settings, etc. Please refer to *System Options*, on page 36.

About Events

Each recording made by the AXIS 2460 Network DVR is the result of a configured *Event*. An event is a set of parameters that define the conditions that must be met before any recording is made. These parameters are time-based or alarm-based, but they can also be a combination of the two. There are also events that run continuously.

Your AXIS 2460 is supplied with five pre-configured events. The first four are named **Manual Recording**, and there is one for each video input/camera. These events are run whenever the camera's Rec button is clicked. These 4 default events can all be disabled, but they cannot be deleted. The fifth pre-configured event is called **Continuous Recording**. This event runs as soon as one or more cameras are enabled. This event can be disabled and/or deleted.

The Recording Options Overview

The screenshot shows the 'Recording Options Overview' page in a Microsoft Internet Explorer browser. The address bar shows the URL: http://123.123.123.123/recOptions/recSet.shtml. The page features a navigation menu on the left with options: Live Quad View, Recordings, Recording Options (selected), Event Settings, Alarm Settings, Camera Options, and System Options. The main content area is titled 'Recording Options Overview' and includes instructions on setting the preferred Recording Mode (Normal, Extended, or Extended Long) and Max Store Time for each camera. The 'Recording Mode' section shows three graphs representing different modes, with 'Extended' selected. The 'Max Store Time' table is as follows:

Camera	Max Store Time
Video In 1 - Camera 1	No Limit
Video In 2 - Camera 2	1 Days
Video In 3 - Camera 3	2 Days
Video In 4 - Camera 4	5 Hours

At the bottom of the table are 'Save' and 'Undo' buttons. The footer of the page displays 'AXIS 2460 Network DVR' and 'Internet'.

The Recording Options Overview allows you to:

- Define the **Recording Mode** to use for the entire system. This will determine how quickly the recordings will be reduced, before eventually being deleted. Select the appropriate radio button for **Normal**, **Extended** or **Extended – Long**. Please see *Recording Storage and Reduction*, on page 49 for detailed information on the recording mode.
- Set a maximum **Store Time** for all the recordings from each connected camera, in hours, days or with no limit. This is useful if, for example, the laws in your country require you to delete recordings after a certain amount of time has elapsed.

Note: The priority assigned to an individual recording is also a factor in determining how long it will be saved for. For more information, see *Priority*, on page 51.

Creating a Simple Event

The tools for creating an event are found among the administration tools under **Recording Options**. Follow these steps to create a simple event that runs only at certain times, with no alarms configured:

1. Click on **Event Settings**.
2. Click on **Add an Event**. The list will be updated with your new event. Click on the **Edit** button to the right.
3. Select the radio button for **During Time Period** under **Event is Activated**. Selecting this will reveal the **Time Period Settings**. Select the days of the week and the start and stop times for the event. Note that these Time Period settings will be used every week, for as long as the event is enabled.
4. Enable the event by checking the box provided. Give your event a suitable name by filling in the **Name** field.
5. Select the **Priority** that will apply for the event. This determines for how long the recordings created by the event will be saved at a higher frame rate. See also *Priority*, on page 51.
6. Select the camera that the event will record from by checking the appropriate box under **Record on Camera**. If several cameras are selected, the event will create recordings from each camera. A unique ID number is appended to each recording so that they can easily be distinguished from each other.
7. Set the **Desired Recording Frequency** to the required setting.
8. Finally, click the **Save** button.

Configuring Alarms

Before setting up an alarm-controlled event, one or more alarm inputs must first be configured.

The AXIS 2460 has four alarm inputs and one output relay. These are configured individually and can be enabled or disabled. The mode of operation is either **Generated When Circuit is Open (Falling)** or **Generated When Circuit is Closed (Rising)**. Note that this applies to the physical alarm devices connected to the Network DVR.

Configuring an Alarm Input

1. Enable the input. This must be done to allow events to use the input. If you have an event that does not use a particular input, then this can be disabled for that particular event, by setting the event to ignore the alarm input.
2. Provide a suitable name for the input, e.g. Fire alarm.
3. Check the device you are using to see if the alarm will be generated when the circuit is open or closed. This setting does not determine if the alarm input is enabled or not, but simply how it functions. Make the setting accordingly.
4. Click **Save**.

Output Relay Settings

When the output relay is enabled on this page it will then be available to all events, which in turn can have the relay enabled or disabled, independently of each other. The settings available are Enabled and Output Name, as described above for inputs.

Creating an Alarm-Controlled Event

Events that use alarms are configured in much the same way as other events. The alarms can be used independently of time settings or in combination with them.

Follow the description below to create an alarm-controlled event:

1. Follow steps 1 to 7 as listed for a simple event, but, in step 3, select the radio button for **When Alarm is Triggered** or **Alarm Triggered during Time Period**. These options will reveal the Time Period Settings and the Alarm Input Settings, respectively.
2. Make the time settings for the event (if used).

3. Under the heading **Alarm Inputs**, select how the event will react to each Alarm Input. The options available are **Active**, **Inactive** or **-----**. The first option means that the alarm must have been triggered, the second that the alarm must be in an untriggered state, and the third option means that the alarm input will effectively be ignored. Note that the criteria for all enabled alarms must be met before the event will begin to record.
4. If the alarm input is marked as **Disabled**, click the Alarm Settings button to go to the alarm configuration page (see above).
5. In the section **Advanced Settings**, you can choose to include a **Pre-Buffer**, which will record immediately before the event, and/or a **Recording Duration**, which specifies a fixed length of time the event will record for, starting from when the event is initially triggered. This length can be set in seconds, minutes or hours. If no Recording Duration is specified, the event will record only for as long as it is active.
6. Click the **Save** button.

Complete Event Settings

The Event Settings list displays all of the events currently configured in the Network DVR.

There is one event predefined for each camera, called **Camera X - Manual Recording**. This manual event can be disabled, but not deleted. It has the same

settings as other events except that it is not possible to define any alarm triggers or to schedule it. This event is triggered when the **Rec** button is pressed.

Event Name	Enabled On Camera...	Rec	Edit	Delete
Server Room - Manual Recording	1		Edit	
Hallway - Manual Recording	2		Edit	
Main Door - Manual Recording	3		Edit	
Pressure - Manual Recording	4	Rec	Edit	
Fire Alarm	2 4	Rec	Edit	Delete
Movement in Server Room	1		Edit	Delete

Events in list: 6 Number of events used by the server: 6 of 100

Add an Event

To add a new event click the **Add an Event** button. Then click the **Edit** button to the right of the event - to enable it, rename it and make other necessary settings, as described below. To delete an event, click the **Delete** button to the right of the event.

The AXIS 2460 can be configured to use a total of 100 events. Events can be removed from the event list, but they cannot be deleted from the server. The text at the bottom of the list shows a) how many events are currently in the list, and b) the total number of events used by the server, out of the maximum of 100. If the limit of 100 events is reached, events can be re-configured to suit new purposes.

Editing Events

The following settings must be made for each event:

Event is Activated...

Select how the event will run. The options are:

- Always - The event runs all of the time
- During Time Period (opens further options - see below)
- When Alarm is Triggered (opens further options - see below)
- When Alarm is Triggered During Time Period (opens further options - see below)

The second and last options are used to specify only certain periods when the event will record. This is useful for configuring events that will e.g. be operational only outside working hours.

Edit Event

Enabled - Check or uncheck this box to activate or deactivate the event.

Priority - The priority given to the event will influence how quickly the **Recording Mode** (see page 20) will run, and consequently, for how long this recording will retain a higher frame rate and be stored for. The higher the priority the slower the reduction. **Top** priority will maintain the high frame rate for approximately 8 times as long as an event at **Low** priority. Note that Normal Priority will not affect the Recording Mode.

Record on Camera - Select the cameras that the event will record from. The event can record on all 4 cameras if necessary. Note that using e.g. 2 cameras will create 2 recordings each time the event is activated.

Name - Provide the event with a suitable name. This name will be used wherever the event is shown. The name can contain up to 20 characters.

Desired Recording Frequency

Select either the maximum rate, or define your own frequency in frames per second, minute or hour. Note that this is the desired frame rate.

Image Resolution	Image Compression	Recording Frequency 1 Camera (NTSC/PAL)	Recording Frequency 4 Cameras (NTSC/PAL)
QCIF (low)	Medium	30/25 fps	7.5/6.25 fps
CIF (medium)	Medium	30/25 fps	7.5/6.25 fps
4CIF (high)	Medium	10/9 fps	3/3 fps

The actual frame rate will depend on the number of enabled cameras and if these cameras

are synchronized or not. When using more than one camera, the frame rate for each camera can be calculated by dividing the frame rate for 1 camera by the number of cameras used. The table shown above features examples of the theoretical frame rates for 1 and 4 cameras, using synchronized cameras. To get the frame rates for 2 or 3 cameras, divide the frequency for 1 camera by 2 or 3, respectively.

Time Period Settings

This section will be displayed only if the Event Type is set as **During Time Period** or as **Alarm Triggered During Time Period**. To configure, specify the days of the week the event will be active, by checking the appropriate boxes. Set the start time and stop time in the fields provided. Please note that these settings will be valid every week until the event is changed or disabled.

Configuring time periods that start on one day and end on the following day is allowed. For example, checking the box for Monday and entering the start time as 21:00 and the stop time as 06:00 means that the event will start on Monday evening and stop on Tuesday morning.

Alarm Input Settings

This section will only be displayed if the Event Type is set as **When Alarm is Triggered** or **Alarm Triggered During Time Period**. Specify for each configured and enabled alarm how and when the event should react to the alarms.

Note: Before the event will record, the conditions for ALL of the configured alarm inputs must first be met. Unless a Recording Duration has been specified, recording will stop as soon as any of these conditions ceases to be valid.

The options for how the events will react are:

- Active - the event will react to the alarm when it has been triggered.
- Inactive - this alarm input must be inactive, that is, it must not have been triggered.
- ----- - this alarm will not affect the event.

These three options can be selected in any combination, e.g.

- Alarm 1 - Active
- Alarm 2 - Inactive
- Alarm 3 - -----
- Alarm 4 - Active

If the alarm input is shown as **Disabled**, click the Alarm Settings button to the right, to go to the alarm configuration page.

Recording Buffer Settings

Pre-Buffer - Specify the length of the period to record immediately preceding the event. Configurable in seconds, minutes or hours. Useful for e.g. seeing what happened immediately before a fire alarm. This setting is optional.

Recording Duration - Specify the length of time to record. Used to specify an exact duration, this setting can be used to e.g. take snapshots of predictable conditions of a constant length and which do not vary. Configurable in seconds, minutes or hours. This setting is optional.

Output Relay

To display the checkbox for the Output relay in the event settings, it must first be enabled on the Alarm Settings page. This will enable the checkbox for all events. Once the checkbox is visible, the output relay can then be enabled or disabled independently for each event. Once the output relay has been activated by the event, it will remain active as long as the event is recording.

If the heading for the Output relay is marked as **Disabled**, click the Alarm Settings button to go to the alarms page.

Send an e-mail to (e-mail address) when this event occurs

E-mail - Check this box to send an e-mail to the specified recipient whenever this event occurs.

Include Image - Checking this box will attach to the e-mail an image from each of the cameras used by the event.

Note: If you see the text **(No Mail Recipient is Specified)**, you must enter an address on the E-mail Settings page. Click the E-mail Settings button to go directly to that page.

Complete Alarm Settings

This section describes how to configure alarms for the four inputs and one output. Note that this describes the configuration of the physical alarm devices connected to the Network DVR. These settings will also influence the behaviour of the alarm LEDs on the front panel.

Input Settings

The following settings can be configured for each input:

Enabled - Check to enable the input. This must always be done if you want the various events to be able to use the input.

Input Name - Used wherever the input is shown. Use a descriptive name.

Generated When Circuit is... - Select **Open (Falling)** or **Closed (Rising)**. The correct setting will depend on the actual device used, and whether it generates an alarm when the circuit closes or when it opens. This setting does not determine if the alarm input is enabled or not, but simply how it functions. Nor does the setting have anything to do with the settings for Active/Inactive on the event settings page.

Output Relay Settings

When the output relay is enabled on this page it will then be available to all events, which in turn can have the relay enabled or disabled, independently of each other. The settings available are **Enabled** and **Output Name**, as described above for inputs.

After making these settings, click **Save**.

Event Examples

These examples mainly cover the alarm input settings and time periods. As our starting point we will use the four alarm inputs

1. **Main Door Open** - A sensor showing that the main door to the building has been opened.
2. **Window Open** - A sensor showing that a window in an exposed location has been opened.
3. **Motion Detected** - A motion detector registering movement outside the boiler room door.
4. **Smoke detected** - A smoke detector located on the ceiling in the boiler room detects smoke.

Four cameras are connected, as follows:

- Camera 1 - Covers main door
- Camera 2 - Covers window
- Camera 3 - Covers passage and door to boiler room
- Camera 4 - Inside boiler room

Example 1 - Smoke detection.

At the simplest level we will always want to make a recording (start an event) if there is smoke in the boiler room. This event should be configured as follows:

1. Check the box for Camera 4.
2. Set the alarm activation to **When Alarm is Triggered**.
3. Set the alarm input settings to 1-----, 2-----, 3-----, 4-Active.
4. Configure a pre-buffer of e.g. 10 minutes, to record what happened immediately before the alarm.

Example 2 - Night time entry.

Records entry through the main door outside working hours.

1. Set the camera to 1.
2. Set the alarm activation to **Alarm Triggered During Time Period**.
3. Set the weekdays and times when the event will be enabled.
4. Set the alarm input settings to 1-Active, 2-----, 3-----, 4-----.
5. Configure a recording duration of 5 minutes.

Example 3 - Entry to Boiler Room at night.

This event should be configured as follows:

1. Set the cameras to 1 and 3.
2. Set the alarm activation to **Alarm Triggered During Time Period**.
3. Set the weekdays and times when the event will be enabled.
4. Set the alarm input settings to 1-Active, 2-----, 3-Active, 4-----.
5. Configure a pre-buffer of e.g. 5 minutes.

Working with Recordings

The Recordings page provides access to all the recordings stored on the AXIS 2460 Network DVR. Each recording is represented by one line in the list. The **Play** button will automatically start the built-in AXIS Video Player and play back the recording. It is also possible, using various criteria, to search for particular recordings.

The AXIS 2460 records and manages the recordings on the connected disks so that disk capacity is always used to its maximum extent. The frame rate of a recorded sequence is reduced over time, so that eventually the recordings are overwritten. The reduction process is fully configurable and is described on page 49. A recording can also be preserved at its original frame rate indefinitely, by *locking* it.

The Recordings List

The recordings list shows the available information for each recording. Clicking any table heading (except Status or Tools) will sort the listing according to that particular criteria. The sort order can be reversed by clicking the same heading once more.

By default, the recordings list displays up to 1000 results, with the recordings currently in progress being displayed first, followed by completed recordings. If there are more than 1000 recordings, there will also be the option to view the following 1000 results.

Recordings/Recordings - AXIS 2460 Network DVR - Microsoft Internet Explorer

Address: http://123.123.123.123/recordings/recordings.shtml?detailed=yes&page=&re

Recordings

Rec ID	Event / Camera	Start / Stop time	Status	Tools
86	Continuous recording Camera 3	Thu Feb 07 14:41:43 2002 Fri Feb 08 13:53:19 2002	REC	Play Lock
88	Continuous recording Camera 2	Thu Feb 07 14:41:43 2002 Fri Feb 08 13:53:22 2002	REC	Play Lock
87	Alarm 1 Camera 2	Thu Feb 07 14:41:43 2002 Thu Feb 07 16:04:50 2002		Play Lock
89	One Minute Camera 1	Thu Feb 07 14:41:43 2002 Thu Feb 07 14:42:42 2002		Play Lock
82	Continuous recording Camera 2	Thu Feb 07 13:53:35 2002 Thu Feb 07 14:31:25 2002		Play Lock
83	Continuous recording Camera 3	Wed Feb 06 20:32:43 2002 Thu Feb 07 14:31:18 2002		Play Lock
84	One Minute Camera 1	Thu Feb 07 10:37:55 2002 Thu Feb 07 10:38:54 2002		Play Lock
81	Continuous recording Camera 3	Wed Feb 06 20:07:08 2002 Wed Feb 06 20:29:17 2002		Play Lock
79	Continuous recording Camera 3	Wed Feb 06 20:04:41 2002 Wed Feb 06 20:06:29 2002		Play Lock
77	Continuous recording Camera 3	Wed Feb 06 19:53:44 2002 Wed Feb 06 20:04:18 2002		Play Lock

Entries / Page: 10 Save Total number of recordings: 28 Update

Page: <<Previous 1 2 3 Next>>

AXIS 2460 Network DVR

Each line in the recordings list shows the following information:

- **Rec ID** - An event will create a recording (or one recording for each camera used by the event) every time it is triggered. This ID number distinguishes different recordings created by the same event.
- **Priority** - Determines how quickly the video frame rate for this recording will be reduced. This is also determined by the setting made on the Recording Options Overview page. See also page 51.
- **Event/Camera** - Shows the name of the event that created the recording, and the camera used to create it.
- **Start/Stop time** - The time when the event started to record and when it ended. Note that if there was a pre-buffer configured, then this will not be reflected in the Start time, nor will it automatically be played back. To view the pre-buffer, restart the recording at the very beginning.
- **Status** - Shows **REC** if the event is currently recording. Also shown is a graded bar denoting the recording's current degree of reduction. The darker green color denotes less reduction, whereas the paler yellow color denotes higher reduction. See also page 52.
- **Tools** - The **Play** button and the **Lock** button.

Viewing a Recording

Find the recording you wish to view. Click on the **Play** button and the AXIS Video Player will start at the point when the event itself started. If there was a pre-buffer configured, then this will not automatically be played back. To view the pre-buffer, restart the recording at the very beginning. For full details on using the player, see page 32.

Searching for a Recording

To search for a particular recording, simply enter the criteria you wish to search by. The search options are: **Camera Name**, **Event Name** and **Time**. The more criteria you enter, the more exact the search results will be. To use a time as search criteria, enter the time in the fields provided and check the box **Include time in search**. After selecting the search criteria, click **Search**.

Searching using time criteria means that the AXIS 2460 will display those recordings that were *running* at that particular time, (i.e. the time can be anywhere in the recording and not necessarily at the start).

The following diagram provides a graphical overview.

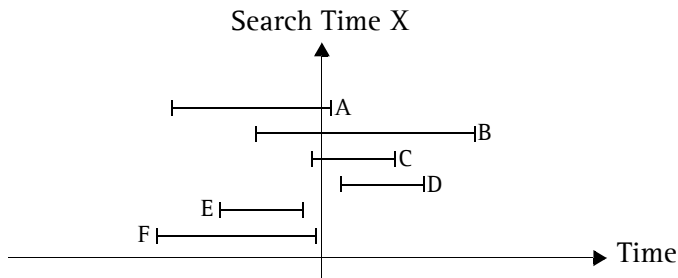



Recordings A, B and C in the diagram will be returned in the search results, as they were running at the specified search time. Recordings, D, E and F will not be included in the search results.

By default, the search function displays up to 1000 results, with the recordings currently in progress being displayed first, followed by completed recordings. If there are more than 1000 recordings that meet the search criteria, there will also be the option to view the following 1000 results.

Locking a Recording

The Tools column in the recordings list shows a small icon that indicates whether or not the recording has been *locked*. A locked recording is equivalent to a *saved* recording. This means that the recording will **not** be affected by the reduction process that otherwise reduces the frame rate and finally erases the recording.

A recording is shown as *Unlocked* by the  icon and as *Locked* by the  icon. A recording can be locked or unlocked at any time, simply by clicking on the icon.

Note: A recording **cannot** be manually deleted. The only way to do this is to reformat the disks, in which case **all** recordings will be deleted.

The AXIS Video Player



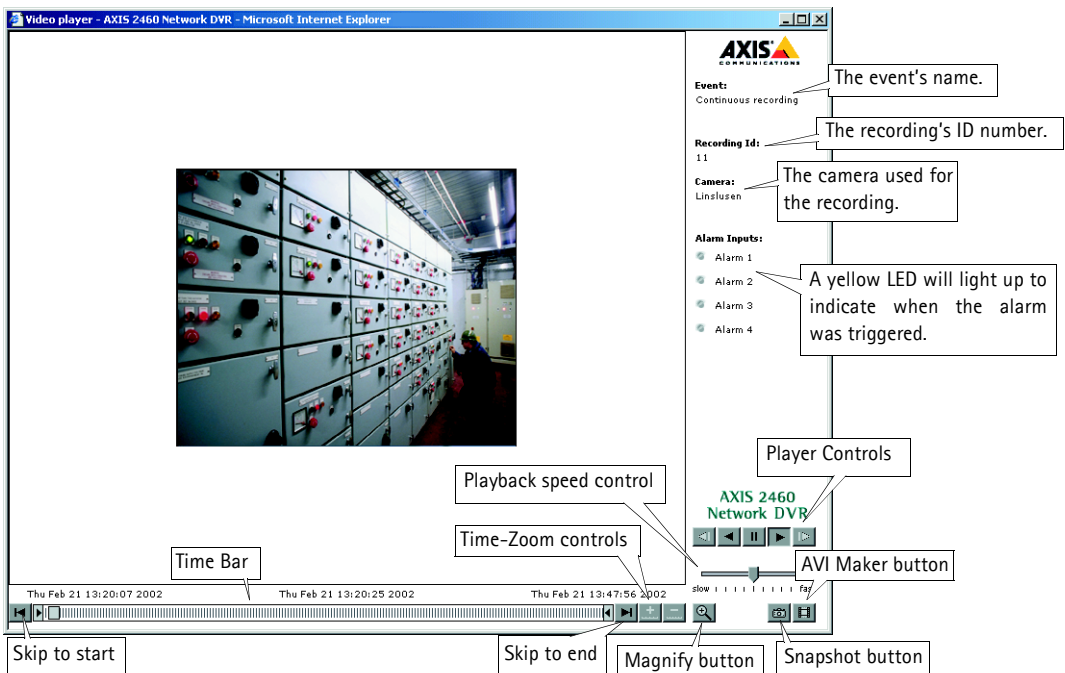

The AXIS 2460 includes the AXIS Video Player for viewing your recordings. The player will start whenever a recording is played back, using the **Play** button in the recordings list. Playback commences automatically, from the start of the event. If there was a pre-buffer configured then this will not automatically be played. To view the pre-buffer, restart the recording at the very beginning.

As well as all the standard controls, the player also provides several other functions, such as; **Time Zoom**, a snapshot function and a tool for creating **AVI-movies**.





Simple Playback

The simplest way to play a recording is to use the player control buttons at the lower right of the player window. These are, from left to right, as follows:

-  Steps backwards one frame at a time
-  Normal playback in reverse
-  Pauses playback
-  Normal playback
-  Steps forwards one frame at a time





It is also possible to click anywhere on the Timebar (the graded bar at the bottom of the screen) to go directly to that position in the recording. The dates and times shown above the Timebar show the approximate position in the recording. The slider control showing the current position in the recording can also be dragged to a new location.

To skip to the beginning of the recording, click the  button. To skip to the end, click the  button. These buttons are located at the very ends of the Timebar.

The playback speed can be adjusted by dragging the slider control shown below the playback buttons.

Time Zoom

The Video Player also has a built-in feature that allows you to focus specifically on a limited section of a recording - Time Zoom. This is very useful if you have a long recording, but only wish to view a short sequence contained in it. Follow the procedure described below to create a Time Zoom view from a recording.

1. On the Timebar, decrease the size of the playback area by dragging the  slider and/or the  slider so that only the section of interest is shown in white. The rest of the recording is now shown in gray. The area in white can be played in the same way as described above for simple playback.
2. To zoom the selection so that it fills the whole of the Timebar, click the Zoom+  icon. The rest of the recording is now hidden from view.
3. Repeat the above procedure if you are not satisfied with the selection you have created.
4. To decrease the amount of space the selection occupies on the Timebar, click the Zoom-  icon. The parts of the recording that were previously hidden are now shown in gray.

To return the recording to its original state, whereby the entire recording occupies all of the Timebar, decrease the size of the selection on the Timebar by clicking the Zoom- icon. If you have zoomed the recording several times, you must also decrease it several times.

Alarm Inputs

Each alarm input is indicated by an LED in the upper right corner of the player window. When playback reaches a point in the recording where an alarm was triggered, this will be indicated by the LED changing color to yellow.

Other Functions

 **Magnify** - Click the Magnify icon to increase the size of the image. Click it again to return to the default size.

 **Snapshot** - To save a JPEG snapshot from a recording, find the point in the recording from which you wish to save a snapshot. You may need to pause the recording, or step it forwards or backwards frame-by-frame. Now click the Snapshot icon. This will open a dialog asking you where to save the snapshot.

Creating an AVI Movie

Clicking the AVI Maker icon  will open a dialog from which you will be able to create an AVI-movie from your recording. This movie can then be distributed to others. A movie can also be created from a Time-Zoom selection, as described above. Follow these steps to create a movie:

1 Set the frame rate for playback and then click the Start button.

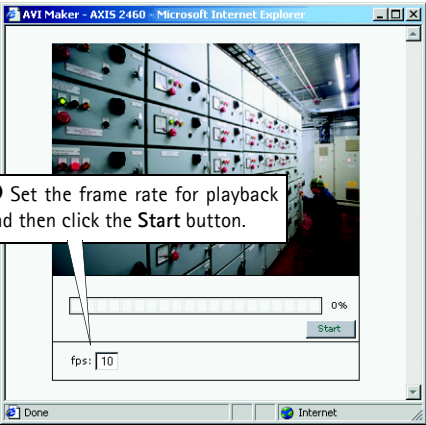

2 Select the compression method. The default setting is usually suitable. Click OK.

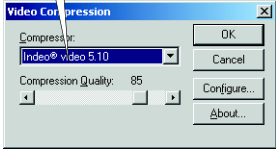

3 The AVI-Maker starts and a progress indicator appears. When the process is finished, the AVI can be played in your standard viewer.

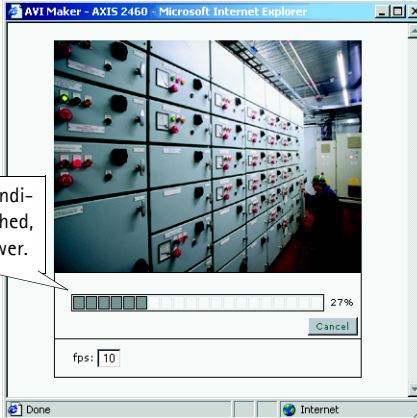

About Codecs

The word codec (as used in this manual) is short for compressor/decompressor. Codecs are various types of computer algorithms that are applied to audio, video, and image files, to compress the size of the files. The benefit of this is that the files do not use as much disk space when stored, or as much network bandwidth when streamed.

The amount and type of compression applied to your AVI-movies depends entirely on the codec used. Most operating systems provide a basic set of codecs, some of which may be suitable for creating AVIs. There are, however, many alternatives available. These can be found by e.g., searching the Internet. It is also important to note that the same codec used for creating the AVI must also be used for viewing it. This should be considered when distributing files to others.

If your computer/player does not have the correct codec to decompress a file, it may attempt to download it. Windows Media Player is one example of an application that will do this.

System Options

This section lists and describes those administration tools used for the general configuration of the AXIS 2460 Network DVR - the **System Options**. The topics covered are, for example, network settings, date and time settings, users, etc. For information on how to set up events, configure alarms, play back recordings, etc., please see the relevant chapters.

Before you begin:

Successful installation of the product is pre-requisite to configuring the unit. You should therefore read the following information before commencing with this section:

- *Network Installation*, on page 12,
- *or Installing via the Null Modem Cable*, on page 15

Important!

Javascript must be enabled in your browser for the AXIS 2460 Web-based interface to work.

After installing the product, your AXIS 2460 is now attached directly to a local area network, or connected to a local PC using the supplied *Null Modem Cable*. You are now ready to proceed with the configuration of the unit, using the System Options.

Note: On-line help is stored internally in the AXIS 2460 and is available from the pages in the Web interface. Containing comprehensive details on all product parameters, the on-line help is your first point of reference when configuring and managing the unit, and is particularly useful for resolving any administration queries.

Important!

- When accessing the AXIS 2460 for the first time, you will be assumed to be the product's administrator and will be logged in as such, with the user name *root* and the default password *pass*.
- You should change the root password as soon as possible. Until this has been done, the security features in the product will not be enabled. Furthermore, all Axis products are shipped with the same password by default. For further information, refer to *Users*, on page 44.
- Prior to accessing the AXIS 2460 over a network, you must first set the IP address with ARP as described on page 12, or with any alternative method as described in *Appendix D - Other IP Setup Methods*.

Accessing The System Options

The Web-based System Options can be used for configuring and managing your AXIS 2460 at any time.

Follow the instructions below to access the System Options from your browser:

1. Start your browser and enter the IP address of the AXIS 2460 in the location/address field. If you are accessing the unit via the Null Modem Cable, you can alternatively enter any text containing a period, for example; my.2460

Example!

`http://123.123.123.123`

2. The AXIS 2460 start page is displayed. Click **Administration** and then **System Options**.

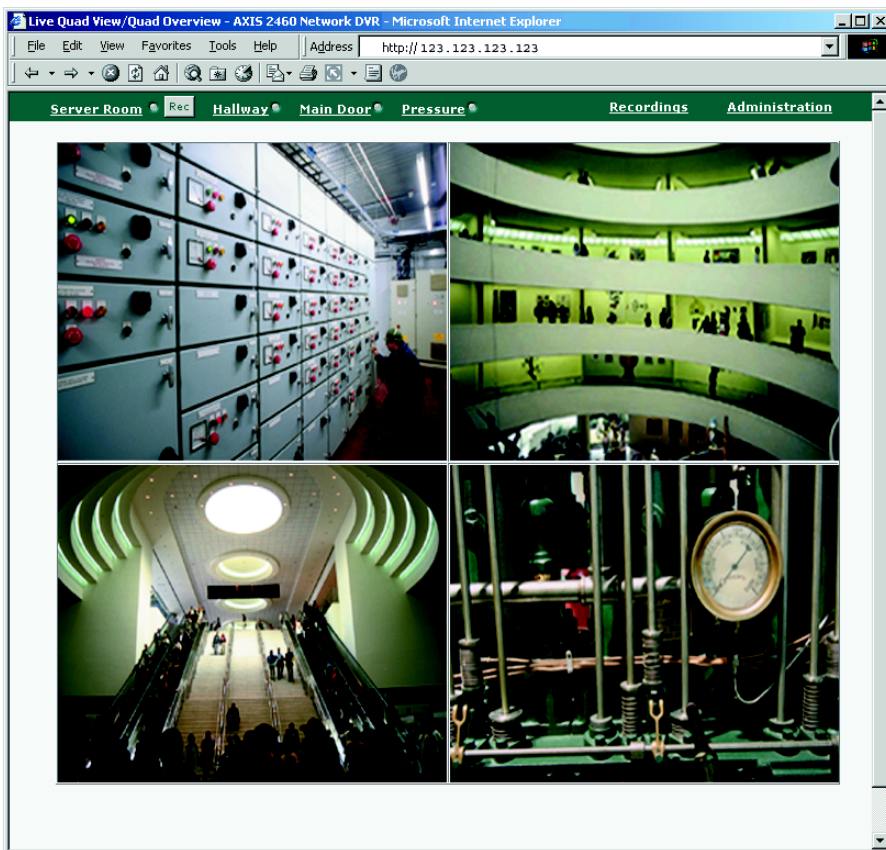

3. The **System Overview** is now displayed. Links to all of the product's functions are presented as; a) links in the left hand margin, b) as a clickable schematic diagram of the unit. Click the relevant link for the parameters or functions you wish to configure. On-line help is available by clicking the yellow question mark at the upper right.

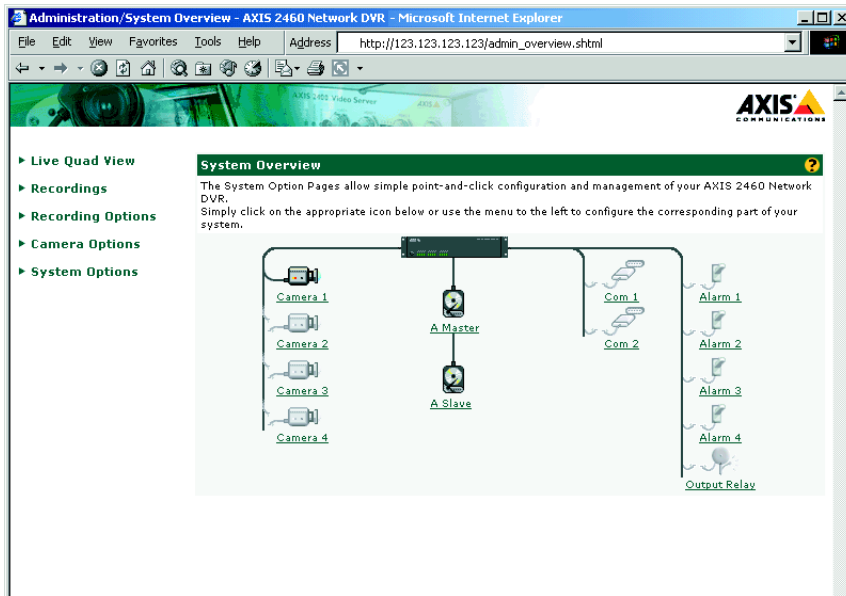

The system is configured and modified directly from these pages. This can be done from any computer that can access the DVR.

System Options Overview

The table below provides a brief overview of the System Options. Each section is explained in more detail in the pages that follow.

Administration	Description	See page
Network Settings	Configure TCP/IP settings, enable BOOTP and restrict bandwidth.	page 39
Mail Settings	Configure SMTP-settings for sending e-mail messages notifying recipients of recordings, error messages, system messages, etc.	page 40
COM-Ports	Configure the COM-ports for Generic TCP/IP, Generic HTTP, or a modem (port 2 only).	page 41
Modem	Configure the connected modem.	page 41
Modem - ISP Settings	Make settings for connecting to your ISP.	page 42
Date & Time	Set the system time, manually or automatically.	page 43
Users	Create and delete users and passwords, and modify the Administrator's password.	page 44
Firewall	Protect your AXIS 2460 against unauthorized access, using the built-in firewall. Allowed IP addresses and protocols can be specified.	page 45
Maintenance	Provides tools for restarting the server, formatting all disks and for resetting to the factory default settings.	page 46
Maintenance - Advanced	Displays information about the connected disks and provides tools for formatting and checking individual disks.	page 46
Support	Provides links to all of the support and help functions for the product.	page 47

Network Settings

From the Network Settings, configure the TCP/IP network settings as follows:

Automatic Configuration

Enable BOOTP - Check this box to use BOOTP to automatically assign an IP address. This requires a BOOTP server on your system.

Manual Configuration

IP Address - Specify a unique 32-bit IP address for your Network DVR, to establish communication with your network. Written as four numbers separated by periods, each number within the address must be in the range 0 - 255. For example: 123.123.123.123

Note: IP addresses can be assigned at random within isolated networks, provided that each given address is unique. To avoid unnecessary number duplication and IP clashes, only use registered IP addresses when connecting to the Internet. It is strongly recommended that you contact your network administrator prior to assigning an IP address for your product.

Default Router - Specify the default router (Gateway) used for connecting to other networks and network segments.

Subnet Mask - Specify the subnet mask for the Network DVR.

Host Name - If you are running a DNS server on your network and wish to connect to the AXIS 2460 using a name, then enter the product's host name here. The host name is usually the same as the assigned DNS Name. A host name is always the first part of a Fully Qualified Domain Name and is always one word, with no period. For example, `myserver` is the host name in the Fully Qualified Domain Name `myserver.axis.com`.

Domain Name - Enter the name of the domain your AXIS 2460 belongs to.

Primary DNS Server - Enter the IP address of the primary DNS server. This specifies the server that normally provides the translation of domain names to IP addresses on your network. If the server is not able to resolve a domain name immediately, it will then distribute the domain name query to other DNS servers on the network.

Secondary DNS Server - Specify the IP address of the secondary DNS server. This is the address of the server normally used to provide the domain name translation if the primary DNS server is unavailable.

HTTP Port - Enter the HTTP port the AXIS 2460 will use. The default setting is 80. Alternatively, any port in the range 1024-65535 may be used, but check first with your system administrator before changing the default setting. See also *Firewall Settings*, on page 45.

Bandwidth Control

Using the **Network Bandwidth Use** drop-down list, it is possible to define the maximum bandwidth used by the DVR. This can help minimize the impact on other services running on your network, which is useful when connecting to busy networks. The options are; 0.1 to 2.0 MBit/s or *Unlimited*.

Mail Settings

The AXIS 2460 can be configured to send event and error e-mail messages to predefined addresses.

Mail Servers

Primary Mail Server - Enter the name or IP address of the server providing your mail facilities.

Secondary Mail Server - Enter the name or IP address of a secondary mail server. This will be used if the primary mail server is unavailable.

Use Modem - Check this box to use a modem for sending e-mail messages. Note that COM-Port 2 must be configured to use a modem.

Event Message Settings

E-mail Address - Specify the recipient for e-mails sent when a recording is made. E-mails will only be sent for those events that have been configured to do this.

System Log Message Settings

The AXIS 2460 can send system log messages (e.g. errors) to notify the recipient that a system event has occurred. After selecting the required level, each time there is an occurrence of this type, a message will be generated. There are 3 levels to choose from:

- **Critical** - This level will show serious errors that require immediate attention and which prevent the unit from functioning properly.
- **Critical and Warnings** - As above, but also shows non-critical errors, e.g. when one of several disks stops functioning.
- **Critical, Warnings and Info** - as above, but also includes information about e.g. completed formatting, notification of restarts, etc.

E-mail Address - Specify the recipient for the e-mail messages sent when the specified system events occur.

Mail Reply Settings

The e-mail address specified here will be used as the reply address included in any e-mail sent by the AXIS 2460 Network DVR.

COM-Ports

The AXIS 2460 Network DVR is supplied with two RS-232 serial ports and one RS-485 serial port. Devices connected to a COM-port on the AXIS 2460 can be accessed via TCP/IP or HTTP. Settings are managed and configured directly from the user interface, simply by clicking the desired port, as described below.

For detailed listings of all of the available settings for each mode, as well as more information about the different interface modes and pinout info, please see *Unit Connectors*, on page 63. The on-line help also provides information on this topic.

The RS-232 ports are connected via the two 9-pin D-sub connectors on the rear of the unit. One of these ports, COM-1, is multiplexed with the RS-485 interface on the I/O-B terminal block connector. The RS-485 port supports the connection of an external device.

The RS-232 port COM-2 can also be used for connecting external devices, but also for connecting a modem.

Both COM-Ports support Generic HTTP and Generic TCP/IP.

Setting the RS-232 Port for use with a Modem (COM-Port 2 only)

From System Options in the Administration tools, select **COM-Port 2** and click the radio button for **Modem**. Click **Save**. To configure the modem, click on the **Modem** link (also from the System Options on the main Administration page).

Modem Settings

If you are intending to use your AXIS 2460 over a dial-up modem connection, define the appropriate communication settings for your modem and click the **Save** button. Note that a modem can be used only on COM-port 2.

Communication Settings

Modem Type - Select a modem from the list of supported V.90 compatible modems in the drop-down list - selecting *Generic* if the modem you want to use does not appear in the list.

Note: Although most external modems are known to work well with the AXIS 2460, only the modems listed in the drop-down list have been fully tested.

Disable Incoming Calls - Check this box if you do not want your modem to answer incoming calls.

Flow Control - Synchronizes the connected modems. **Hardware** flow control is accomplished by enabling the Control to Send (CTS) and Return to Send (RTS) signals for the serial interface. If using **Software** control, the modems will still be synchronized, but the flow control will use XON/XOFF. If using **NONE**, there will be no synchronization.

Baud Rate (bps) - Set the baud rate for the connected modem.

Init String - This defines the Attention Code (AT) command sent when starting the dial-up connection, to initialize the connected modem. Using the Attention Code ATz (the common code for initializing most commercial modems), the Network DVR will normally configure the port settings for the connected modem automatically.

If you enter your own string here and it proves incompatible with your connected modem, click the **Default** button to reset the string to the default value.

Important!

If the communication settings are not displayed after clicking **Save**, it is likely that the default initialization string used by the AXIS 2460 is incompatible with your modem. In this case, you must enter the correct initialization string for the connected modem and click **Save** once again.

ISP Settings

Provide the contact information used for connecting to your ISP.

Internet Service Provider - Enter the service provider's name.

Phone Number - This is the telephone number, including any regional code, to your ISP. Country codes should also be provided if you are dialing internationally.

User Name - ISP subscribers are provided with a unique user name and password. Enter your user name here.

Password - Enter the password associated with your user name.

Redial Attempts - Define the number of dial-up attempts the Network DVR should make to the host modem/ISP before timing-out; that is, before it stops trying to establish a modem connection.

Redial Interval - Defines how soon after an unsuccessful dial-up attempt the Recorder will try again.

Date & Time

Click **Date and Time** to define the time and date settings for your AXIS 2460, either manually or automatically, as described below.

Current Network DVR Time

Shows the current date and time.

New Network DVR Time

Synchronize with computer time - Sets the time according to the clock on your computer.

Synchronize with NTP Server - This option will cause the AXIS 2460 to obtain the correct time from an NTP server. Specify the NTP server's IP address or DNS name and set the appropriate time zone for the Recorder's location.

Set manually - Using this option allows you to manually enter the time and date.

Automatically adjust for daylight saving time changes - Check this box to automatically update the time changes caused by daylight saving.

Important!

If a user or an NTP-server puts the clock back, this may lead to there being several recordings from the same point in time (although they were actually recorded at different times). This might also mean that a recording ends before it starts! (at least according to the local time seen by the user). Most importantly, all of the recordings stored on the AXIS 2460 are always available - even if the clock is set back.

Users

To prevent any unauthorized use of the product, the AXIS 2460 supports multi-user password protection, where access is restricted to defined users only, of which there can be a maximum of 20. An Administrator has unrestricted access to the product's administration tools and can determine the registration and rights for all other users.

The Users list displays all the users authorized to use the Network DVR.

Important!

When accessing the AXIS 2460 and the administration tools for the first time, you will be assumed to be the Administrator and will be logged in as such, with the user name *root* and the default password *pass*. The root password should be changed as soon as possible. When this has been done, the product's security features will be enabled, and access to the Administration tools will be restricted to defined users only.

Although changing the Administrator's password restricts access to the Admin tools, by default, the AXIS 2460 will still allow anonymous viewing access, which means that anybody on the network can access the product's images in a browser. To restrict open viewing access, simply register at least one authorized user. This stops the anonymous viewing service and only allows specified users to access the images.

All Axis products are shipped with the same password by default.

Adding Users

The following fields must be completed for each new user

- User Name - must contain at least one, but not more than fourteen characters.
- Password - must contain at least four, but not more than fourteen characters.
- Confirm Password - repeat the above password here.

User Rights - Check the appropriate boxes to define the access rights and privileges for each specified user; where the level of user access can be described as follows:

- Administrator - An Administrator has unrestricted access to the administration tools and can consequently determine the registration of all other users.
- Operator - An Operator can adjust recorder and camera settings, as well as start, stop and view recordings.
- View - Provides the lowest level of access, which only allows the user to see live images, to see recordings and to start or stop a recording manually.
- Dial-In - Optionally allows the user to access the AXIS 2460 via a dial-in connection.

After making the settings for the new user, click the **Add/Change** button. This button only updates the list locally. To save the settings, click the **Save** button.

Deleting Users

To delete a user, highlight the name in the User list and click the **Delete** button. This will update the user list locally. To save the changes, click the **Save** button.

Changing the properties for existing Users

Select the user, make the necessary changes and click the **Add/Change** button. This updates the user list locally. To save the changes, click the **Save** button.

Firewall Settings

The built-in firewall protects your AXIS 2460 against unauthorized access. To restrict access, you can add IP addresses to the list of allowed addresses - no others will be permitted access.

Enable/Disable Firewall - Click this button to enable or disable the firewall function.

Allowed IP Addresses - This list box shows the currently configured IP addresses.

Adding Allowed IP Addresses

IP Address - Add a single IP address or a whole range of addresses. This last option can be useful if you have a large number of IP addresses that all need access to the Network DVR. To add a range of addresses type e.g. 123.123.123.* This will add all the addresses in the range 123.123.123.00 to 123.123.123.255. Up to 256 allowed IP addresses can be specified.

Allow - Check the boxes for the protocols that users will be allowed to use to access the Network DVR. These can be FTP and/or HTTP. See below for special considerations concerning HTTP.

TCP Port no. - If you have particular requirements concerning which ports access will be allowed on, enter these here. To allow HTTP (see above) the port value must correspond to the value set on the *Network Settings* page. If this is set to some other value than 80 (the default setting), then this value must be added manually in this field. If the setting on the Network Settings page is 80, then nothing needs to be configured here.

After adding the above information click the **Add New** button or the **Save** button to save the changes.

Note: If you are accessing the AXIS 2460 via a proxy server, the proxy server's IP address must be added to the list of allowed IP numbers.

Deleting and Modifying the Properties for Allowed IP Addresses

To delete an IP address, select it in the list and click the **Delete** button. To modify an IP address, select it from the list of allowed addresses, make the necessary changes and then click the **Save** button.

Maintenance

This section provides tools for the following:

- **Restart** - This will restart the DVR.
- **Clean** - Erases **ALL** recordings and formats **ALL** of the hard disks.
- **Restore** - Erases and formats all disks and resets the DVR to its factory default settings. See also the description of how to reset to the factory default settings on page 48.

Maintenance - Advanced

The advanced maintenance function provides tools for maintaining the installed disks. The information and tools for each disk are as follows:

Model - Shows the brand of disk and the bus it is mounted on.

Status - The symbols reflect the disk's current status as follows:



Signifies that the disk is connected and being used by the DVR to store images.



The disk is connected, but is not currently being used to store images, probably due to a corrupt file system. Run error checking or format the disk before attempting to use it.



The drive cannot be used as it is either being formatted or having its file system checked.

Size - The total disk capacity, shown in Gigabytes.

Error Checking - Click the **Check** button to check the disk for errors. No recordings can be made on this disk whilst error checking is in progress. If other healthy disks are present, then any recording will continue on those disks instead.

Formatting - Click the **Format** button to format a single disk. Select either a **Quick** format or a **Low Level** format. Quick formatting replaces the disk's file system and Low Level fixes physical faults. If all the disks need to be formatted, use the **Clean** function on the **Maintenance** page.

Important!

Formatting will permanently erase all the information stored on the disk. The Format button is only available for a disk that actually needs formatting.

Support

This section of the System Options provides various information and reports, which may be useful when troubleshooting. The following items are available:

Parameters - This link displays a listing of all of the AXIS 2460's parameters and their current settings. This list should be included when requesting help from the support desk.

Server Report - The Server Report displays a listing of important information about the AXIS 2460. If you need to contact the Axis Support desk for help with a problem, please include this report with your query.

Log Files - This link opens a page that shows buttons for opening the available log files, that is; the **Info** Log, the **Warning** Log and the **Critical** Log. These log files can be useful when troubleshooting the product, or if you should need to contact support services.

Release Notes - Information about the components included in the firmware release.

About - Displays information about the development of the product.

The Factory Default Settings

In certain circumstances, it may be necessary to reinstate the **Factory Default** settings for your AXIS 2460. This is performed in one of two ways:

- By pressing the **Factory Default Button**, located on the rear panel. This option will reset **ALL** the parameters currently configured in the unit, i.e. network settings, events, etc.
- By clicking the **Restore** button from the **Maintenance** page under System Options. This action will reset most of the unit's parameters but will save the IP-address, the Subnet mask, the Default Router and the Mac (Ethernet) address.

Follow the instructions below to reinstate the product factory default settings using the Control Button:

1. Switch off the AXIS 2460 by pressing the Power button on the front panel.
2. Press and hold the Factory Default Button pressed, and press the Power button again.
3. Keep the Factory Default Button pressed until the Status Indicator displays *yellow* (note that this may take up to 15 seconds), then release the Control Button. When the Status Indicator displays *green* (which can take up to several minutes) the AXIS 2460 will then have been reset to the original factory default settings.

Note: Both methods of resetting to the factory default settings will also format all the connected hard disks.

Appendix A – Recording Storage and Reduction

The AXIS 2460 records and manages the stored images on the connected disks so that the storage capacity is always used to its maximum extent. Once the disks are filled, something must be done to make space available for new recordings. The AXIS 2460 does this by gradually reducing the frame rate of recorded sequences so that eventually there are no more frames and the recording has effectively been deleted. An important recording that needs to be kept at its original frame rate *indefinitely* can be explicitly *locked* and thus protected against the reduction process.

The rate and amount of frame rate reduction for an individual recording is controlled by a number of factors:

- the **Recording Mode** set for the whole system
- the **Priority** set for the event that created the individual recording
- other factors that affect file size and thus hard disk space, e.g. image resolution, image compression, etc.

Selecting the Recording Mode

The technology used for image storage on the AXIS 2460 is called APViS™ (Axis Prioritized Video Storage). This technology (invented by Axis and patent pending) extends the length of time recordings are stored for by intelligently reducing the frame rate of all recordings not explicitly locked. Older recordings and those of less importance (see *Priority* below) will thus gradually be reduced until finally deleted.

As the available recording modes all describe a ratio between the length of time the recordings are stored for and the frame rate at which they stored, you should consider what you require from your recordings when selecting the mode.

- **Normal Mode** - a standard FIFO (First In - First Out) algorithm that simply overwrites older recordings with new ones, with no prior reduction in frame rate. Normal mode will keep all of your recordings at the original frame rate for their entire lifespan, but they will be overwritten relatively quickly.
- **Extended Mode** - stores recordings for longer than Normal mode, but at the expense of frame rate reductions in older and less important recordings.
- **Extended Long Mode** - extends storage time by using even greater reduction, and even earlier in the recording. This mode also reduces the frame rate of more recent recordings. If you need to save recordings for as long as possible and can accept the highest degree of frame rate reduction, then this is the best choice.

The recording mode will apply to the whole system and is selected on the *Recording Options Overview* page in the administration tools. The following diagrams provide a graphical overview of how a recording (identical in all three cases) will be reduced and stored by the different recording modes.

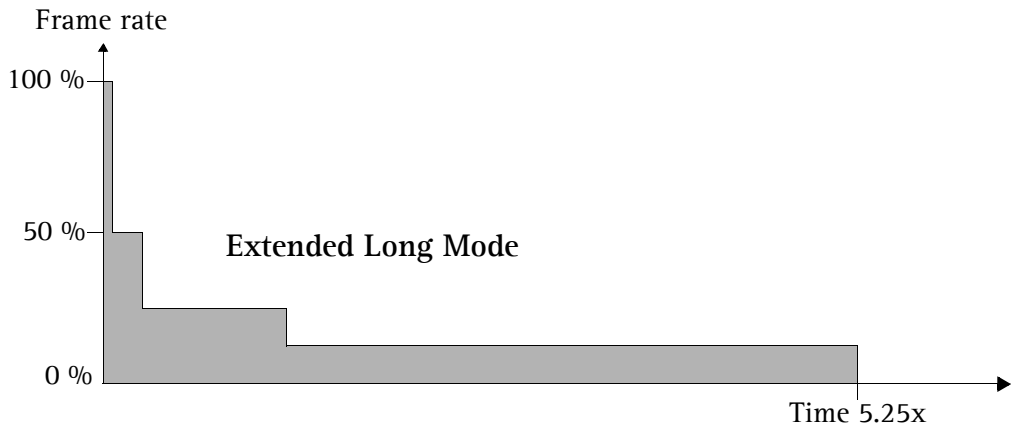
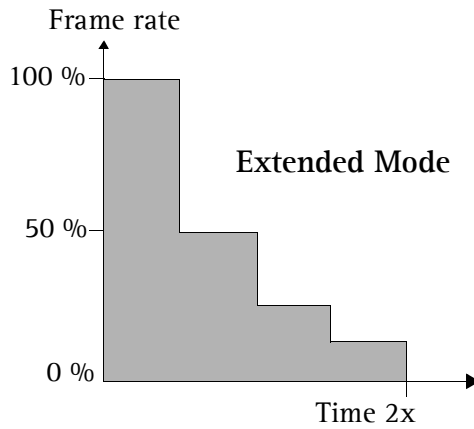
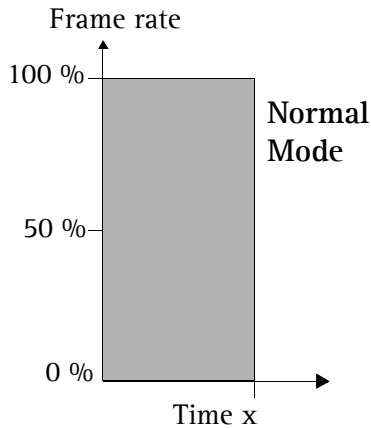

While Normal mode has kept the frame rate at 100% the whole time, the other modes have reduced the recording. Extended mode has reduced the frame rate at roughly equal intervals, and saved the recording for roughly twice as long. Extended Long mode has quickly reduced the recording to a much lower frame rate, which is then maintained for much longer.

Approximate Storage Times

The table below shows approximations of: a) the total recording storage time in days and, b) the number of days until the first frame rate reduction. These are shown as *total/first reduction*. The basis for the examples is as follows:

- four 40 GB hard disks installed
- a recording frame rate of 1 fps per camera
- recording on 4 cameras from an indoor office scene.

Image Resolution	Modulation		Image Compression	Image file size	Storage Time for Recording Mode		
	NTSC	PAL			Normal	Extended	Extended Long
QCIF (low)	176 x 112	176 x 144	High	3 kB	126/-	268/67	702/11.5
QCIF	176 x 112	176 x 144	Normal	4 kB	94/-	199/50	522/8.5
QCIF	176 x 112	176 x 144	Low	8 kB	45/-	96/24	253/4
CIF (Normal)	352 x 240	352 x 288	High	8 kB	45/-	96/24	253/4
CIF	352 x 240	352 x 288	Normal	13 kB	27/-	57/14	149/2.5
CIF	352 x 240	352 x 288	Low	17 kB	20/-	42/10	110/2
4CIF (High)	704 x 480	704 x 576	High	24 kB	13/-	28/7	73/1
4CIF	704 x 480	704 x 576	Normal	36 kB	7.5/-	16/4	43/0.5
4CIF	704 x 480	704 x 576	Low	61 kB	3.5/-	7/1.5	18/0.3





Priority

If the Recording Mode is best explained as a function that reduces the frame rate of recordings stored in the AXIS 2460, then **Priority** can be described as the means of controlling the *speed* of the Recording Mode. The higher the priority, the more the reduction process will be slowed down. The maximum storage time (i.e. the slowest reduction) for a recording will thus be achieved by setting the Recording Mode to *Extended Long* and the event's priority to *Top*.

It is also important to understand that priority is *comparative*, that is, it will only be relevant when there are recordings that use different priorities. Setting e.g. Top priority for *all* events/recordings would be meaningless.

An event's Priority is set when creating the event.







The available priorities are as follows:

-  Top Priority - Slows the reduction process down the most.
-  High Priority
-  Normal Priority - This is the default level for a new event.
-  Low Priority

Note: None of the available Priority levels will affect the Normal Recording Mode.

Status

The status icon shown for each individual recording in the recordings list shows the current degree of reduction, as explained here:

-  The recording has not yet been reduced.
-  Slight reduction at start of recording.
-  50% reduction throughout.
-  Some reduction at start of recording, none at end.
-  75% reduction throughout.
-  The oldest parts of the recording have now been deleted.
-  Reduced throughout. This recording will soon be deleted.

Note: To prevent an individual recording from being reduced, click the Lock button for that recording.

Appendix B - The LED Indicators

The front panel LED indicators use different colors to indicate the unit's status. The various indications are as follows:

Indicator	Green	Amber	Red
Power	Normal Operation.	Goes to amber when powering down.	
Network	Flashes for 100 Mbit activity.	Flashes for 10 Mbit activity.	Solid red indicates no network connection.
Disk	Flashes green when reading from the disk.	Flashes amber when writing to the disk.	Flashes red for a non-functional disk. Shows solid red if ALL disks are out of action.
Status	Normal operation.		Flashes red slowly to indicate an illegal serial number. Return the unit to Axis.
Video	Video signal present, but no recording in progress.	Video signal present and recording in progress.	No video signal.
Alarm	The alarm inputs will show yellow whenever an alarm is triggered on the input.		

- Notes:**
- The indicators will also show amber at initial power to the unit, as well as green and/or red during the unit's start-up phase. This is normal and does not indicate a malfunction.
 - The Power indicator flashes green and amber during a firmware upgrade.

Appendix C - Troubleshooting

This appendix provides useful information to help you to resolve any difficulty you might have with your AXIS 2460. Symptoms, possible causes and remedial actions are provided in a quick reference table.

Checking the Firmware

One of your first actions when attempting to solve a problem should be to check the firmware version currently installed. An updated version may contain a correction that fixes your particular problem. For more information, please see *Updating the Firmware*, on page 60.

PINGing Your IP Address

By sending a packet to the specified address and waiting for a reply, the *PING* utility can determine whether a specific IP address is accessible. It also provides a particularly useful method for confirming addressing conflicts with your AXIS 2460 on the network.

Follow the instructions below in association with *Symptoms, Possible Causes and Remedial Actions*, on page 55, and run PING to troubleshoot TCP/IP problems on your network:

1. Start a Command window.
2. Type `ping x.x.x.x`, where `x.x.x.x` is the IP address of the AXIS 2460.
3. If you receive the reply `destination host unreachable`, then the AXIS 2460 is not accessible on your subnet. You must obtain a new IP address and reinstall the unit. Please see *Installing the AXIS 2460 Network DVR*, on page 12.
4. If this does not solve the problem, disconnect the AXIS 2460 from the network and run the PING command again. See the table below for an interpretation of the results.

PING Reply	Interpretation and recommendation
Reply from <IP address>: bytes = 32; time = 10 ms.....	The IP address is already in use and cannot be used again. You must obtain a new IP address.
Request timed out	This IP address is not used and is available for use with your AXIS 2460. If you already installed the unit using this IP address, the installation may have failed. In this case, reinstall the unit. See page 12. Also check all cabling.

Symptoms, Possible Causes and Remedial Actions

Symptoms	Possible causes	Remedial actions
The AXIS 2460 cannot be accessed from a browser.	The IP address is already being used by another device.	<ol style="list-style-type: none"> 1. Disconnect your AXIS 2460 from the network. 2. Run the PING utility (as described in <i>PINGing Your IP Address</i>, on page 54) and follow the appropriate recommendations. <p>Note: The assigned IP number can be assumed valid if the PING utility returns "request timed out" - in which case you should set the IP address again, power-up the unit and then try accessing it again.</p>
	The IP address is located on a different subnet.	<p>Run the PING utility (as described in <i>PINGing Your IP Address</i>, on page 54). If this returns no response or similar, then this diagnosis is probably correct.</p> <p>In Windows, check that the IP address for your AXIS 2460 is on the same subnet as your workstation. Exactly how this is done varies from one version of Windows to another. See Windows' help for more information.</p> <p>If your AXIS 2460 and your workstation are on different subnets, you will not be able to set the IP address. Contact your network administrator.</p>
	The IP address has changed.	Check that there is no BOOTP server running on your network.
	Possible problem with your proxy server.	Try disabling the proxy default in your browser.
	Other networking problems.	<p>Test the network cable by connecting it to some other network device and then PINGing that device from your workstation.</p> <p>Test the network interface by connecting a local computer to the unit, using a standard <i>Crossover (hub-to-hub) Cable</i>.</p> <p>If the above actions do not resolve the problem, the AXIS 2460 may be faulty. In this case, try to localize the problem by connecting the unit to the serial port of a local computer, using the supplied <i>Null Modem Cable</i> and report your findings to your local distributor.</p>
The AXIS 2460 works locally, but not externally.	Firewall protection.	Check the Internet firewall with your system administrator.
	Default routers required.	Check if you need to configure the default router settings.
	Proxy not specified.	Add the proxy server to the list of allowed IP addresses.
The Network indicator displays red.	Faulty cabling.	See "Other networking problems" above.
The Status indicator flashes red at long intervals.	Illegal serial number.	Contact your Axis dealer.
The Disk indicator flashes red at short intervals.	Hard disk disconnected or non-functional.	Run error checking and/or format the faulty disk.
The Disk indicator is solid red.	ALL hard disks disconnected or non-functional.	Run error checking and/or format the disks.
Video indicator(s) solid red.	Lost video signal.	Check the cabling, the power to the camera and the camera settings.
No image using Refresh and/or slow updating of images.	Multiple clients attempting to access the images.	Try limiting the number of clients.

Symptoms	Possible causes	Remedial actions
Cannot access the connected modem.	Faulty configuration.	Check that the COM-port is set to use a modem and that the modem is correctly configured.
	Faulty cabling.	Check the power supply and the serial connection.
Poor quality images.	The Display Properties are incorrectly configured for your desktop.	Open the Display Properties in your desktop and configure your display to show at least 65000 colors, i.e. at least 16-bit. Note: Using only 16 or 256 colors on your computer will produce dithering artifacts in the image.
	The camera is not focused correctly.	Refocus the camera(s).
The Video Player does not function / no live images.	ActiveX disabled.	Make sure that ActiveX is enabled in Microsoft Internet Explorer.
	Wrong browser	Microsoft Internet Explorer must be used to view live images and recordings.

Note: If you still have a problem after reading this information, please contact your reseller or check the AXIS 2460 product pages on the Axis Website at www.axis.com.

Appendix D - Other IP Setup Methods

In addition to the ARP command (described earlier in the installation section of this manual), you can alternatively set the IP address for your AXIS 2460 using any of the following methods - as appropriate for your operating system:

Method	Operating Systems	See also...
BOOTP Requiring a BOOTP daemon on your system, this method operates over the entire network. A request to an active daemon initiates a search of the boot table to find an entry matching the unit's Ethernet address. The daemon replies with the IP address for the device, if a match is found.	UNIX	
AXIS IP Installer	Windows	<i>Using the AXIS IP Installer, on page 58</i>

- Notes:**
- Do not use the default or IP address featured in these examples when installing your AXIS 2460. If in doubt, consult your network administrator to obtain an unused IP address.
 - Make sure the AXIS 2460 is powered up and attached to the network.
 - Server Privileges: Although no special privileges are required for Windows 98, ME or XP (Home), you do need *Administrator* privileges for Windows NT, 2000 and Windows XP (Professional). UNIX systems require *Root* privileges.
 - Ethernet/Mac Address: The AXIS 2460 is pre-configured with a unique Ethernet/Mac address based upon the serial number printed on the label on the rear of the unit; where the serial number typically follows the format 00-40-8c-xx-yy-zz. You must know the Ethernet/Mac address to complete the installation.

Using the AXIS IP Installer

AXIS IP Installer is a Windows program that is ideal for setting the IP addresses for multiple Axis networking products on your network. Also allowing you to access the home Web page of any Axis device connected to your network, this freely distributed software is available for download from www.axis.com.

Installing the AXIS IP Installer:

1. Download the latest version of the AXIS IP Installer and run the *Setup_IPInstaller.exe* program to start the installation.
2. The AXIS IP Installer - Setup dialog is displayed on the screen.
3. Follow the instructions as they appear on the screen.
4. Click **Finish** to complete the installation.

Setting the IP Address with AXIS IP Installer:

1. Run the AXIS IP Installer from the Start menu. The following window will appear:

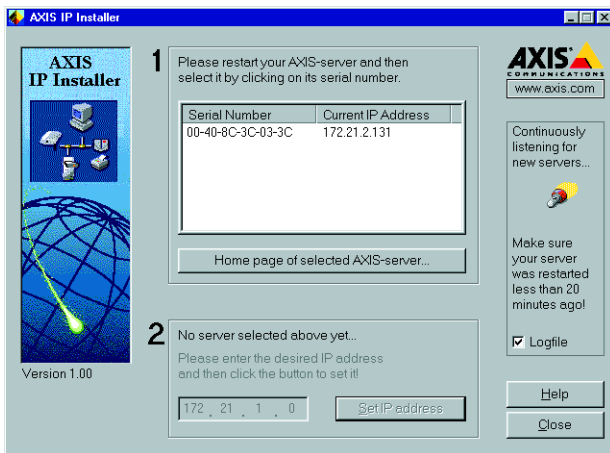

2. Restart the AXIS 2460.
3. Select the serial number of your AXIS 2460 in the list. The serial number is identical to the unit's Ethernet/Mac address.
4. Enter the IP address. Click **Set IP address**. The IP address will now be set.
5. To access the home page of the AXIS 2460, click **Home page of selected Axis-server...** You can now configure the AXIS 2460 according to your requirements.
6. Click **OK** to exit the program.

For more help during the installation of the IP address, click **Help** or press the F1 key.

Notes for Macintosh Users

Important!

The AXIS 2460 was developed for use with Microsoft Internet Explorer (5.0 or higher) running on Windows 98/ME/XP/NT or 2000. This is because the viewing of live images and the built-in Video Player both require an ActiveX control for their function, something which is currently only supported by Internet Explorer. Other browsers and other operating systems can be used for installing the unit and also for administration purposes, but the Video Player will not function correctly.

The AXIS 2460 supports TCP/IP over Ethernet, or PPP Modem dial-up. You must use TCP/IP on your Macintosh network, as there is no support for AppleTalk.

When using the AXIS 2460 on a Macintosh, please observe the following points:

- The DVR has a default IP address of 192.36.253.80.
- Assign a temporary IP address to a Mac workstation in the same subnet (e.g. 192.36.253.81) and then connect to the DVR.
- Reset the correct IP address for the Macintosh workstation.
- Changing the IP address for a Macintosh does not require a reboot.

Appendix E - Updating the Firmware

The AXIS 2460 firmware is stored in Flash memory. This memory is provided by a silicon chip that, just like any other ROM device, retains data content even after power is removed. Flash memory is unique because it allows its data to be erased and rewritten. This means that you can install firmware updates for your AXIS 2460 as soon as they become available - without having to replace any parts. New firmware can be simply loaded into the AXIS 2460 over the network.

Checking the Firmware Version

To check which firmware version is currently installed, click the link to the [Release Notes](#) in the support section of the Administration tools.

Obtaining Updated Firmware

The latest version of the AXIS 2460 camera firmware is available free of charge from the Axis website at www.axis.com or from your local distributor.

Updating the Firmware

The AXIS 2460 Flash memory is updated over the network using FTP. See the detailed instructions supplied with each new release.

Important!

- Always read the instructions available with each new release, prior to updating your software.
- Downloading normally takes at least 30 seconds and up to 10 minutes, although it can take longer. After starting the download, you should always wait at least 20 minutes before power-cycling the AXIS 2460 - even if you suspect the download procedure has failed.
- In controlled environments, flash memory updates provide a very safe method for updating firmware. However, flash products can become damaged if the update operation is not performed correctly. Your dealer reserves the right to charge for any repair attributable to faulty updating.

Appendix F - Installing Hard Disks

The AXIS 2460 can be fitted with various brands of commercially available IDE hard disk. For more information about recommended brands, please visit www.axis.com and see the product pages for the AXIS 2460.

Follow these instructions to install a disk:

1. Switch off power to the unit. First press the power button on the front panel until it turns amber and wait until the unit shuts down. Then set the main power switch on the rear panel to 0.
2. Mount the disk(s) in the holder(s).
3. Set the disk in the upper position to *master*. If installing a second disk on the same cable (channel) set this to *slave*. Exactly how this is done varies from one type of disk to another. Refer to the documentation provided with the disk.
4. Remove the cover from the AXIS 2460. Connect the IDE-cable to the disk(s) and connect the other end to the motherboard.

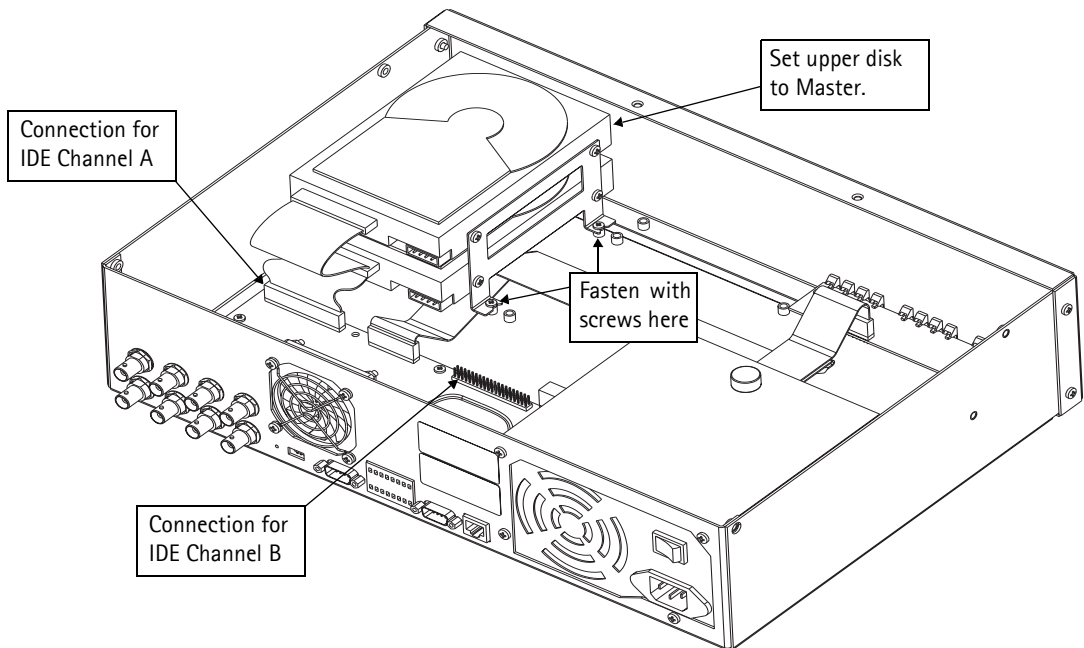

5. Connect the power cable to the disk(s).
6. Screw the disk holders in place inside the unit, using 2 screws on each side. Use a magnetic screwdriver.

7. Replace the cover and screw it back into place. Set the main power switch to I. The AXIS 2460 will now automatically detect and format the new disk(s).

Note: If the disk you installed has been used previously (a valid partition table will be detected), it will not be formatted. In this case the disk must be formatted manually, either by selecting **Clean** from the **Maintenance** menu, which formats all the connected disks, or by formatting the individual disk from the **Maintenance - Advanced** menu.

Any disk errors in the AXIS 2460 are indicated by the **Disk LED** on the front panel. This will flash red if one of several installed disks is not functioning, and it will show a solid red if none of the disks are functioning.

Appendix G - Unit Connectors

This section provides an overview of the product's connectors, namely:

- 2 x RS-232 Serial Connectors
- 1 x I/O Terminal Block Connector
- 4 x BNC Video Inputs
- 4 x BNC Video Outputs
- 1 x Ethernet network connector (RJ-45)

The RS-232 Serial Connectors

In the absence of a local network connection, the 9-pin D-sub connector COM2 provides a dedicated physical interface for connecting a modem or computer to the AXIS 2460. This RS-232 interface supports modem speeds of up to 115kbps and effectively allows the AXIS 2460 to operate as a standalone unit, independent of any computer network. The maximum cable length for RS-232 should not exceed 15 meters (50 feet).

If a local network connection is unavailable at the point of installation, you can simply connect your PC to this connector using the supplied *Null Modem Cable*. This will allow you to complete the initial configuration of your product.

Both serial connectors (COM1 and COM2) can be used for running Generic TCP/IP or Generic HTTP applications. The pinout for COM1 is different to that of COM2.

Note: Axis Communications maintains a list of all supported modems. Please visit our Website at www.axis.com for this and other late information on our products.

Pinout Information

A diagram of the RS-232 connectors, complete with pinout information, is shown below.

COM1 Pinout	
Pin	Function
1	Not connected
2	RXD (Receive Data)
3	TXD (Transmit Data)
4	RTS (Return To Send)
5	GND (Ground)
6	DSR (Data Signal Ready)
7	RTS (Request To Send)
8	Not connected
9	Not connected

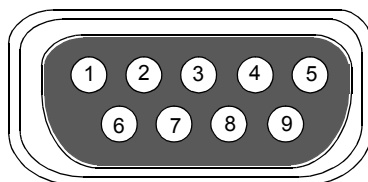

COM2 Pinout	
Pin	Function
1	CD (Carrier Detect)
2	RXD (Receive Data)
3	TXD (Transmit Data)
4	DTR (Data Terminal Ready)
5	GND (Ground)
6	DSR (Data Signal Ready)
7	RTS (Request To Send)
8	CTS (Clear To Send)
9	RI (Ring Indicator)

The I/O Terminal Block Connector

Typically used in association with programming scripts for developing applications for event triggering, alarm notification via e-mail, etc., the 16-pin I/O Terminal Block is located on the rear panel and provides the interface to: a single relay switch output, four digital photo-coupled inputs, and an RS-485 interface. See page 66 for more information about RS-485.

This section describes the pinout, interface support and the control and monitoring functions provided by this connector.

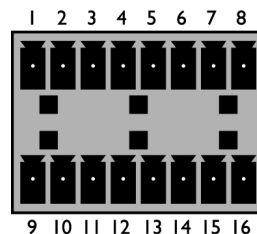

Connector Pinout

The pinout for the Terminal Block (*illustrated above*) and signaling details for each pin is fully described in the table below:

Pin	Function	Description
1	Not connected.	
2	Not connected.	
3	Digital Input 3 - Photocoupler Anode (+)	Photocoupled Input 3: Electrically isolated from the chassis and connectors, this input can be supplied from an external DC voltage or the DC Power Input/Output on pins 9 and 10. Driven by 5-24V.
4	Digital Input 3 - Photocoupler Cathode (-)	
5	Digital Input 4 - Photocoupler Anode (+)	Photocoupled Input 4. As above.
6	Digital Input 4 - Photocoupler Cathode (-)	
7	RS-485 - B (inverting)	Serial Port 1- RS-485. A half-duplex RS-485 interface for controlling auxiliary equipment. Note: Serial Port 1 is programmed as either RS-232 (COM1 Connector) or RS-485 (Terminal Block Connector), via the browser interface.
8	RS-485 - A (non-inverting)	
9	DC + Power Output 12V	This can drive the photo coupler inputs or other equipment; such as an IR-sensor. A maximum current of 50mA can be sourced from the DC output. Pin 10 is connected to the unit chassis and to Ground on each serial port and video input. See the schematic diagram on page 67.
10	DC - Power Output	
11	Digital Input 1 - Photocoupler Anode (+)	Input 1 Photo coupler input. As Input 3.
12	Digital Input 1 - Photocoupler Cathode (-)	
13	Digital Input 2 - Photocoupler Anode (+)	Input 2 Photo coupler input. As Input 3.
14	Digital Input 2 - Photocoupler Cathode (-)	
15	Relay Switch	Relay switch - electrically isolated from chassis and connectors.
16	Relay Switch	

Note: For compatible replacement connectors, please contact Axis. Alternatively, contact <http://www.phoenixcontact.com>, quoting: MC1.5/8-ST-3.81 (art no 1803633).

Controlling and Monitoring

By entering http requests in your browser's URL field, you can:

- drive the relay output high or low
- monitor the status of the 4 digital inputs

This requires you to have root access to the AXIS 2460 and consequently, to supply a user name and password. Login as *root* and supply the root password (default = *pass*).

Tip!

Developers wishing to create applications incorporating sophisticated alarm conditioning using the relay output and digital inputs are encouraged to read the Camera API, HTTP-Interface Specification, available from the Axis Web at www.axis.com

Relay Output

You can use the supported relay output to directly drive a maximum load of 24V AC/DC at 100mA. By connecting additional relay circuitry, it can also drive heavier loads.

The output relay is controlled using http requests, as defined in the following examples:

Example 1: - Set output 1 ON.

```
http://myserver/axis-cgi/io/output.cgi?action=1:/
```

Example 2: - Set two 300ms pulses with 500ms delay between the pulses on output 1.

```
http://myserver/axis-cgi/io/output.cgi?action=1:/300\500/300\
```

Example 3: - Wait 1 second before setting output 1 ON.

```
http://myserver/axis-cgi/io/output.cgi?action=1:1000/
```

Digital Inputs

Four digital inputs allow the AXIS 2460 to be configured for time and alarm based image recording. For example, by connecting a motion detector to a digital input, it is a relatively simple procedure to send a single image (or video stream) to a remote imaging library each time the detector is activated. These inputs can be driven by voltages of 5-24V.

Querying the Status of Digital Inputs

The status of the four supported digital inputs can be queried in exactly the same way as the relay output. Simply enter the following URL to query the status of the digital inputs:

Example: - Monitor data on input ports 1, 2, 3, and 4.

```
http://myserver/axis-cgi/io/input.cgi?check=1,2,3,4
```

The AXIS 2460 then displays the status of the inputs, as follows:

Input 1 = 0
Input 2 = 1
Input 3 = 0
Input 4 = 0

The BNC Video Inputs

4 BNC composite video inputs with 75 Ohm/Hi Z termination. Autosensing for NTSC and PAL. Each video input is terminated using a coax/BNC connector. Physical connections are made using RG59, 75 Ohm coax video cable. The recommended maximum cable length is 800 feet (250 meters).

The BNC Video Outputs

4 BNC video outputs that can be used for connecting the AXIS 2460 to a traditional analog CCTV system or to a VCR. This output can be used independently of the Ethernet network connector and both can be used at the same time. The video output signals are connected directly to the video input signals (loopthroughs).

The Ethernet Network Connector

The RJ-45 network connector is used to connect the AXIS 2460 to a 10/100Mbit Ethernet network running TCP/IP.

About RS-485

RS-485 is a standard for transmitting data over multi-drop communications line. Supporting up to 32 drivers and 32 receivers over a single twisted pair cable, the maximum cable length should not exceed 1220 meters (4000 feet). Typically used for connecting a single master (e.g. a PC) to several addressable devices over the same cable. The master decides which slave speaks and the slaves only speak when spoken to, by raising RTS.

The AXIS 2460 will act as either a master or a slave, depending on how communication is initiated. RS-485 is similar to RS-232, but without a signal ground. Data detection is by measuring the voltage difference between the positive and negative line. This eliminates disturbance by interference, because interference appears identically on both lines simultaneously. This means greater distances can be covered than with RS-232.

Schematic Diagram - With Possible Applications

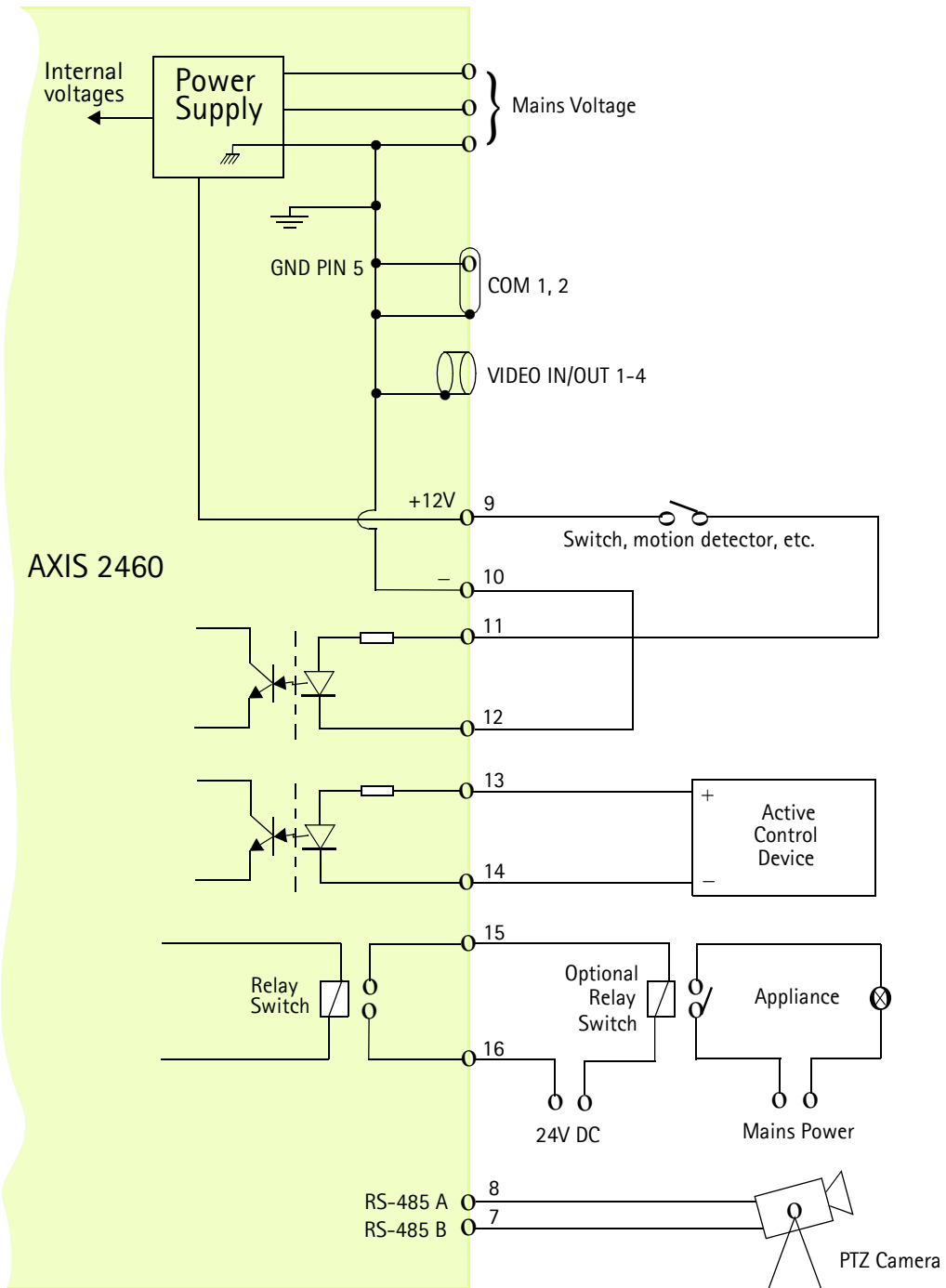

Appendix H – Technical Specifications

System Requirements – Microsoft Internet Explorer 5.0 or higher, running on Windows 98, ME, XP, NT or 2000. Other browsers on other operating systems (e.g. Linux, UNIX, Mac) can be used for installing the product and for administrative purposes, but live images and the Video Player will not function correctly.

Networking Protocols – The AXIS 2460 uses the standard TCP/IP suite of protocols.

Installation – Physical network connection using RJ-45 twisted pair cable, or remote connection using any standard serial modem. The product is intended for indoor use only.

Management – Remote configuration and status using Web-based Administration Tools.

Image Features – Time/date stamp, text overlay, variable size, color CGI control.

Image Resolution

- Low: 176 x 112 (NTSC), 176 x 144 (PAL)
- Normal: 352 x 240 (NTSC), 352 x 288 (PAL)
- High: 704 x 480 (NTSC), 704 x 576 (PAL)

Networking – 10baseT Ethernet or 100baseTX Fast Ethernet, TCP/IP, HTTP, FTP, SMTP, NTP, ARP and BOOTP.

I/O Connector – Used for connecting external alarm devices, e.g. temperature sensors and switches. Provides one relay switch output, four digital photo-coupled inputs, an RS-485 interface, and auxiliary power.

RS-232 Connectors

- COM-1 – RS-232, max 230 Kbps. Multiplexed with the RS-485 port on the terminal block.
- COM-2 – RS-232, max 38.4 Kbps, half-duplex. A modem is connected here.

RS-485 – Available from terminal block connector.



Video Inputs – 4 BNC composite video inputs with 75 Ohm/Hi Z termination. Autosensing for NTSC and PAL.

Video Outputs – 4 BNC video loop-through ports.

Security – Multi-user password protection. Built-in Firewall. Allowed IP addresses can be specified.

Operating Conditions: – Temp: 41-104^o F (5-40^oC), Humidity: 8-80% RHG.

Approvals EMC

- FCC Class A
-  EN55022 Class B, EN55024
-  C-Tick

Approvals Safety - EN60950, C-UL

Dimensions

- Height: 100mm (3.9")
- Width: 430mm (16.9")
- Depth: 320mm (12.6")

Weight

- No disks - 7.0 kg (15.4 lbs)
- 2 disks - 8.2 kg (18.1 lbs)
- 4 disks - 9.4 kg (20.7 lbs)

Hardware

- CPU - 32-bit RISC processor (ETRAX 100 LX v.2)
- Flash memory - 4 Mb
- RAM - 32 Mbyte
- ARTPEC-1 compression chip.

Complimentary Software

- AXIS IP Installer for quick installation of multiple units. Available from the Axis web site.
- The AXIS Camera Controller, the AXIS AVI Maker and the AXIS Video Player are ActiveX components required when using Microsoft Internet Explorer. These components are automatically installed the first time the product is used.

Networking Technology - Incorporating Axis ThinServer Technology, the AXIS 2460 is a truly embedded system and self-contained product, based on the Linux operating system and including the most popular network protocols and Web management tools. The hardware is built on Axis' own ETRAX-100LX 32-bit RISC processor, which is streamlined and optimized for device connectivity to networks, independent of any other network resource. The AXIS 2460 uses the industry's first dedicated network digital video surveillance compression chip - the AXIS ARTPEC-1.

All specifications are subject to change without prior notice.

Index

A

Alarm indicators 9
Alarm input settings 25
Alarm-controlled events 22
Allowed IP addresses 45
AVI-Movies 34
AXIS IP Installer 57

B

Bandwidth control 40
BNC Video Output 66
Boa Web server 8
BOOTP 39, 57
Browsers - supported 12

C

CGI scripts 7
Codecs 35
COM-Ports 10, 41, 45
Compression 7
Configuring alarms 23
Configuring cameras 18
Connectors 63
Continuous Recording 20
Creating an AVI-Movie 34
Creating an event 21

D

Date & time settings 43
Dial-up Networking 16
Digital inputs and output 65
Dipswitch 10
Disk indicator 9

E

Editing events 24
Enabling cameras 18
Event examples 27
Event messages 40

Event settings 23

Events 20

F

Factory Default Button 10
Factory Default Settings 48
Firewall settings 45
Firmware update 60
Front panel 9

H

Hard disks 61
Hardware inventory 11

I

I/O Terminal Block 64
Indicators 53
Installation
 Hard disks 61
 Modem 15
 Network 12
IP address 39, 57
IP setup methods 57
ISP settings 42

L

LED indicators 53
Line termination switch 10
Linux 8
Locking a Recording 31

M

Macintosh 59
Mail settings 40
Manual Recording 20
Maximum store time 21
Microsoft Internet Explorer 12, 59
Modem installation 15
Modem settings 41
Mounting the unit 11

N

- Network indicator 9
- Network installation 12
- Network settings 39
- Null Modem Cable 15

O

- Other IP setup methods 57
- Output relay 26
- Output relay settings 22

P

- Passwords 44
- PINGing the IP Address 54
- Playback 32
- Power button 9
- PPP 7
- Pre-buffer 26
- Priority 52

R

- Rear panel 10
- Recording duration 26
- Recording mode 21
- Recording options 20
- Recordings 29
- Reduction of recordings 52
- Relay output 64, 65
- RS-232 connector 63
- RS-232 port - using a modem 41
- RS-485 66

S

- Searching for a Recording 30
- Send e-mail 26
- Serial connector 63
- Setting up Events and Alarms 20
- SMTP 7
- Specifications 68
- Status indicator 9
- Store time 21
- System Log messages 40

- System options 36

T

- Technical specifications 68
- Terminal block connector 10
- Time period settings 25
- Time Zoom 33
- Troubleshooting 54

U

- Updating the firmware 60
- Users 44

V

- Verifying the installation 14
- Video indicators 9
- Video inputs 10
- Video outputs 10
- Video Player 32
- Viewing a Recording 30